

Model PH90

Combination Freezer

Operating Instructions

047772-M



2/00

Complete this page for quick reference when service is required:

Taylor Distributor: _____

Address: _____

Phone: _____

Service: _____

Parts: _____

Date of Installation: _____

Information found on data plate:

Model Number: _____

Serial Number: _____

Electrical Specs: Voltage _____ Cycle _____
Phase _____

Maximum Fuse Size: _____ Amps

Minimum Wire Ampacity: _____ Amps

Part Number: _____

© February, 2000 Taylor
All rights reserved.
047772-M



*The word Taylor and the Crown design
are registered trademarks in the United States
of America and certain other countries.*

Taylor Company
a division of Carrier Commercial Refrigeration, Inc.
750 N. Blackhawk Blvd.
Rockton, IL 61072

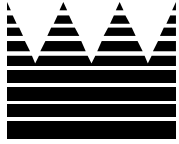

Table of Contents

Section 1	To the Installer	1
	Installer Safety	1
	Site Preparation	1
	Air Cooled Units	2
	Water Connections (Water Cooled Units Only)	2
	Electrical Connections	2
	Beater Rotation	3
	Refrigerant	3
Section 2	To the Operator	4
Section 3	Safety	5
Section 4	Operator Parts Identification	7
Section 5	Important: To the Operator	15
	Symbol Definitions	15
	Power Switch	16
	Indicator Lights	16
	Flavor Selector Keypad	16
	Liquid Crystal Display	16
	Heater Switch	16
	Reset Mechanism	16
	Adjustable Draw Handle	17
	Operating Screen Descriptions	17
	Operator Menu	20
Section 6	Operating Procedures	23
	Equipment Set Up	23
	Freezing Cylinder Assembly - Shake Side	23
	Freezing Cylinder Assembly - Soft Serve Side	27
	Mix Hopper Assembly	31
	Sanitizing - Shake Side	35
	Sanitizing - Soft Serve Side	37
	Priming - Shake Side	39
	Priming - Soft Serve Side	40
	Daily Closing Procedures	40
	Daily Opening Procedures	44
	Syrup System	47
	Syrup Pump	50

Manual Brush Cleaning	55
Draining Product From The Freezing Cylinder	55
Rinsing	56
Cleaning and Sanitizing	57
Disassembly - Shake Side	57
Disassembly - Soft Serve Side	58
Brush Cleaning	59
Sanitizing the Syrup System	60
Section 7 Important: Operator Checklist	61
During Cleaning and Sanitizing	61
Troubleshooting Bacterial Count	61
Regular Maintenance Checks	61
Winter Storage	62
Section 8 Troubleshooting Guide	63
Section 9 Parts Replacement Schedule	75
Section 10 Parts List	76
Wiring Diagrams	96

Note: Continuing research results in steady improvements; therefore, information in this manual is subject to change without notice.

© February, 2000 Taylor
All rights reserved.
047772-M



*The word Taylor and the Crown design
are registered trademarks in the United States
of America and certain other countries.*

Taylor Company
a division of Carrier Commercial Refrigeration
750 N. Blackhawk Blvd.
Rockton, IL 61072

Section 1

To the Installer

The following are general installation instructions. For complete installation details, please see the check out card.

Installer Safety



In all areas of the world, equipment should be installed in accordance with existing local codes. Please contact your local authorities if you have any questions.

Care should be taken to ensure that all basic safety practices are followed during the installation and servicing activities related to the installation and service of Taylor equipment.

- Only authorized Taylor service personnel should perform installation and repairs on the equipment.
- Authorized service personnel should consult OSHA Standard 29CFR1910.147 or the applicable code of the local area for the industry standards on lockout/tagout procedures before beginning any installation or repairs.
- Authorized service personnel must ensure that the proper PPE is available and worn when required during installation and service.
- Authorized service personnel must remove all metal jewelry, rings, and watches before working on electrical equipment.



The main power supply(s) to the freezer must be disconnected prior to performing any repairs. Failure to follow this instruction may result in personal injury or death from electrical shock or hazardous moving parts as well as poor performance or damage to the equipment.

Note: All repairs must be performed by an authorized Taylor Service Technician.



This unit has many sharp edges that can cause severe injuries.

Site Preparation

Review the area the unit is to be installed in before uncrating the unit, making sure that all possible hazards the user or equipment may come into have been addressed.

For Indoor Use Only: This unit is designed to operate indoors, under normal ambient temperatures of 70°-75°F (21°-24°C). The freezer has successfully performed in high ambient temperatures of 104° (40°C) at reduced capacities.



This unit must **NOT** be installed in an area where a water jet or hose can be used. **NEVER** use a water jet or hose to rinse or clean the unit. Failure to follow this instruction may result in electrocution.



This unit must be installed on a level surface to avoid the hazard of tipping. Extreme care should be taken in moving this equipment for any reason. Two or more persons are required to safely move this unit. Failure to comply may result in personal injury or equipment damage.

Uncrate the unit and inspect it for damage. Report any damage to your Taylor Distributor.

This piece of equipment is made in the USA and has USA sizes of hardware. All metric conversions are approximate and vary in size.

This machine is designed for indoor use only.



DO NOT install the machine in an area where a water jet could be used. Failure to follow this instruction may result in serious electrical shock.

Air Cooled Units

DO NOT obstruct air intake and discharge openings:

Air cooled units require a minimum of 3" (76 mm) of clearance around **all** sides of the freezer to allow for adequate air flow across the condensers. Install the deflector provided to prevent recirculation of warm air. Failure to allow adequate clearance can reduce the refrigeration capacity of the freezer and possibly cause permanent damage to the compressors.

Water Connections

(Water Cooled Units Only)

An adequate cold water supply must be provided with a hand shut-off valve. On the rear of the unit, two 1/2" I.P.S. water connections for inlet and outlet have been provided for easy hook-up. 1/2" inside diameter water lines should be connected to the machine. (Flexible lines are recommended, if local codes permit.) Depending on local water conditions, it may be advisable to install a water strainer to prevent foreign substances from clogging the automatic water valve. There will be only one water "in" and one water "out" connection. **DO NOT** install a hand shut-off valve on the water "out" line! Water should always flow in this order: first, through the automatic water valve; second, through the condenser; and third, through the outlet fitting to an **open trap drain**.



A back flow prevention device is required on the incoming water connection side. Please refer to the applicable National, State, and local codes for determining the proper configuration.

Electrical Connections

In the United States, this equipment is intended to be installed in accordance with the National Electrical Code (NEC), ANSI/NFPA 70-1987. The purpose of the NEC code is the practical safeguarding of persons and property from hazards arising from the use of electricity. This code contains provisions considered necessary for safety. In all other areas of the world, equipment should be installed in accordance with the existing local codes. Please contact your local authorities.



FOLLOW YOUR LOCAL ELECTRICAL CODES!

Each unit requires one power supply for each data label on the unit. Check the data label on the freezer for fuse, circuit ampacity and other electrical specifications. Refer to the wiring diagram provided inside of the electrical box, for proper power connections.



CAUTION: THIS EQUIPMENT MUST BE PROPERLY GROUNDED! FAILURE TO DO SO CAN RESULT IN SEVERE PERSONAL INJURY FROM ELECTRICAL SHOCK!



This unit is provided with an equipotential grounding lug that is to be properly attached to the rear of the frame by the authorized installer. The installation location is marked by the equipotential bonding symbol (5021 of IEC 60417-1) on both the removable panel and the equipment's frame.



- Stationary appliances which are not equipped with a power cord and a plug or another device to disconnect the appliance from the power source must have an all-pole disconnecting device with a contact gap of at least 3mm installed in the external installation.
- Appliances that are permanently connected to fixed wiring and for which leakage currents may exceed 10 mA, particularly when disconnected, not used for long periods, or during initial installation, shall have protective devices such as a GFI to protect against the leakage of current, installed by authorized personnel to the local codes.
- Supply cords used with this unit shall be oil-resistant, sheathed flexible cable, not lighter than ordinary polychloroprene or other equivalent synthetic elastomer-sheathed cord (Code designation 60245 IEC 57) installed with the proper cord anchorage to relieve conductors from strain, including twisting, at the terminals and protect the insulation of the conductors from abrasion.

Beater Rotation



Beater rotation must be clockwise as viewed looking into the freezing cylinder.

Note: The following procedures must be performed by an authorized Taylor service technician.

To correct rotation on a three-phase unit, interchange any two incoming power supply lines at freezer main terminal block only.

To correct rotation on a single-phase unit, change the leads inside the beater motor. (Follow diagram printed on motor.)

Electrical connections are made directly to the terminal block. The terminal block is provided in the main control box located behind the panel in the rear of the syrup compartment.

Refrigerant



In consideration of our environment, Taylor proudly uses only earth friendly HFC refrigerants. The HFC refrigerant used in this unit is R404A. This refrigerant is generally considered non-toxic and non-flammable, with an Ozone Depleting Potential (ODP) of zero (0).

However, any gas under pressure is potentially hazardous and must be handled with caution.

NEVER fill any refrigerant cylinder completely with liquid. Filling the cylinder to approximately 80% will allow for normal expansion.



Refrigerant liquid sprayed onto the skin may cause serious damage to tissue. Keep eyes and skin protected. If refrigerant burns should occur, flush immediately with cold water. If burns are severe, apply ice packs and contact a physician immediately.



Taylor reminds technicians to be cautious of government laws regarding refrigerant recovery, recycling, and reclaiming systems. If you have any questions regarding these laws, please contact the factory Service Department.



WARNING: R404A refrigerant used in conjunction with polyolester oils is extremely moisture absorbent. When opening a refrigeration system, the maximum time the system is open must not exceed 15 minutes. Cap all open tubing to prevent humid air or water from being absorbed by the oil.

Section 2

To the Operator

The freezer you have purchased has been carefully engineered and manufactured to give you dependable operation. The Taylor Model PH90, when properly operated and cared for, will produce a consistent quality product. Like all mechanical products, this machine will require cleaning and maintenance. A minimum amount of care and attention is necessary if the operating procedures outlined in this manual are followed closely.

This Operator's Manual should be read before operating or performing any maintenance on your equipment.

Your Model PH90 will NOT eventually compensate and correct for any errors during the set-up or filling operations. Thus, the initial assembly and priming procedures are of extreme importance. It is strongly recommended that personnel responsible for the equipment's operation, both assembly and disassembly, study these procedures in order to be properly trained and to make sure that no misunderstandings exist.

In the event you should require technical assistance, please contact your local authorized Taylor Distributor.

Note: Warranty is valid only if the parts are authorized Taylor parts, purchased from an authorized Taylor Distributor, and the required service work is provided by an authorized Taylor service technician. Taylor reserves the right to deny warranty claims on equipment or parts if non-approved parts or refrigerant were installed in the machine, system modifications were performed beyond factory recommendations, or it is determined that the failure was caused by neglect or abuse.

Note: Constant research results in steady improvements; therefore, information in this manual is subject to change without notice.



If the crossed out wheeled bin symbol is affixed to this product, it signifies that this product is compliant with the EU Directive as well as other similar legislation in effect after August 13, 2005. Therefore, it must be collected separately after its use is completed, and cannot be disposed as unsorted municipal waste.

The user is responsible for returning the product to the appropriate collection facility, as specified by your local code.

For additional information regarding applicable local laws, please contact the municipal facility and/or local distributor.

Compressor Warranty Disclaimer

The refrigeration compressor(s) on this machine are warranted for the term indicated on the warranty card accompanying this machine. However, due to the Montreal Protocol and the U.S. Clean Air Act Amendments of 1990, many new refrigerants are being tested and developed, thus seeking their way into the service industry. Some of these new refrigerants are being advertised as drop-in replacements for numerous applications. It should be noted that, in the event of ordinary service to this machine's refrigeration system, **only the refrigerant specified on the affixed data label should be used.** The unauthorized use of alternate refrigerants will void your compressor warranty. It will be the owner's responsibility to make this fact known to any technician he employs.

It should also be noted that Taylor does not warrant the refrigerant used in its equipment. For example, if the refrigerant is lost during the course of ordinary service to this machine, Taylor has no obligation to either supply or provide its replacement either at billable or unbillable terms. Taylor does have the obligation to recommend a suitable replacement if the original refrigerant is banned, obsoleted, or no longer available during the five year warranty of the compressor.

The Taylor Company will continue to monitor the industry and test new alternates as they are being developed. Should a new alternate prove, through our testing, that it would be accepted as a drop-in replacement, then the above disclaimer would become null and void. To find out the current status of an alternate refrigerant as it relates to your compressor warranty, call the local Taylor Distributor or the Taylor Factory. Be prepared to provide the Model/Serial Number of the unit in question.

We at Taylor Company are concerned about the safety of the operator when he or she comes in contact with the freezer and its parts. Taylor has gone to extreme efforts to design and manufacture built-in safety features to protect both you and the service technician. As an example, warning labels have been attached to the freezer to further point out safety precautions to the operator.



IMPORTANT - Failure to adhere to the following safety precautions may result in severe personal injury or death. Failure to comply with these warnings may damage the machine and its components. Component damage will result in part replacement expense and service repair expense.



DO NOT operate the freezer without reading this Operator Manual. Failure to follow this instruction may result in equipment damage, poor freezer performance, health hazards, or personal injury.



This unit is provided with an equipotential grounding lug that is to be properly attached to the rear of the frame by the authorized installer. The installation location is marked by the equipotential bonding symbol (5021 of IEC 60417-1) on both the removable panel and the equipment's frame.



DO NOT use a water jet to clean or rinse the freezer. Failure to follow these instructions may result in serious electrical shock.



- **DO NOT** operate the freezer unless it is properly grounded.
- **DO NOT** operate the freezer with larger fuses than specified on the freezer data label.
- **DO NOT** attempt any repairs unless the main power supply to the freezer has been disconnected. Contact your local authorized Taylor Distributor for service.
- Stationary appliances which are not equipped with a power cord and a plug or another device to disconnect the appliance from the power source must have an all-pole disconnecting device with a contact gap of at least 3mm installed in the external installation.
- Appliances that are permanently connected to fixed wiring and for which leakage currents may exceed 10 mA, particularly when disconnected, not used for long periods, or during initial installation, shall have protective devices such as a GFI to protect against the leakage of current, installed by authorized personnel to the local codes.
- Supply cords used with this unit shall be oil-resistant, sheathed flexible cable, not lighter than ordinary polychloroprene or other equivalent synthetic elastomer-sheathed cord (Code designation 60245 IEC 57) installed with the proper cord anchorage to relieve conductors from strain, including twisting, at the terminals and protect the insulation of the conductors from abrasion.

Failure to follow these instructions may result in electrocution. Contact your local authorized Taylor Distributor for service.



- **DO NOT** allow untrained personnel to operate this machine.
- **DO NOT** operate the freezer unless all service panels and access doors are restrained with screws.
- **DO NOT** remove any internal operating parts (examples: freezer door, beater, scraper blades, etc.) unless all control switches are in the OFF position.

Failure to follow these instructions may result in severe personal injury to fingers or hands from hazardous moving parts.



This unit has many sharp edges that can cause severe injuries.

- **DO NOT** put objects or fingers in the door spout. This may contaminate the product and cause severe personal injury from blade contact.
- **USE EXTREME CAUTION** when removing the beater assembly. The scraper blades are very sharp.
- **CAUTION-SHARP EDGES:** Two people are required to handle the cup/cone dispenser. Protective gloves must be worn and the mounting holes must NOT be used to lift or hold the dispenser. Failure to follow this instruction can result in personal injury to fingers or equipment damage.



DO NOT draw product during the HEAT cycle because of high product temperatures.



This freezer must be placed on a level surface. Failure to comply may result in personal injury or equipment damage.



Cleaning and sanitizing schedules are governed by your state or local regulatory agencies and must be followed accordingly. Please refer to the cleaning section of this manual for the proper procedure to clean this unit.

DO NOT obstruct air intake and discharge openings:

Air cooled units require a minimum of 3" (76 mm) minimum air space all sides. Install the deflector provided to prevent recirculation of warm air. Failure to follow this instruction may cause poor freezer performance and damage to the machine.

For Indoor Use Only: This unit is designed to operate indoors, under normal ambient temperatures of 70° - 75°F (21° - 24°C). The freezer has successfully performed in high ambient temperatures of 104° (40°C) at reduced capacities.

NOISE LEVEL: Airborne noise emission does not exceed 78 dB(A) when measured at a distance of 1.0 meter from the surface of the machine and at a height of 1.6 meters from the floor.

Section 4

Operator Parts Identification

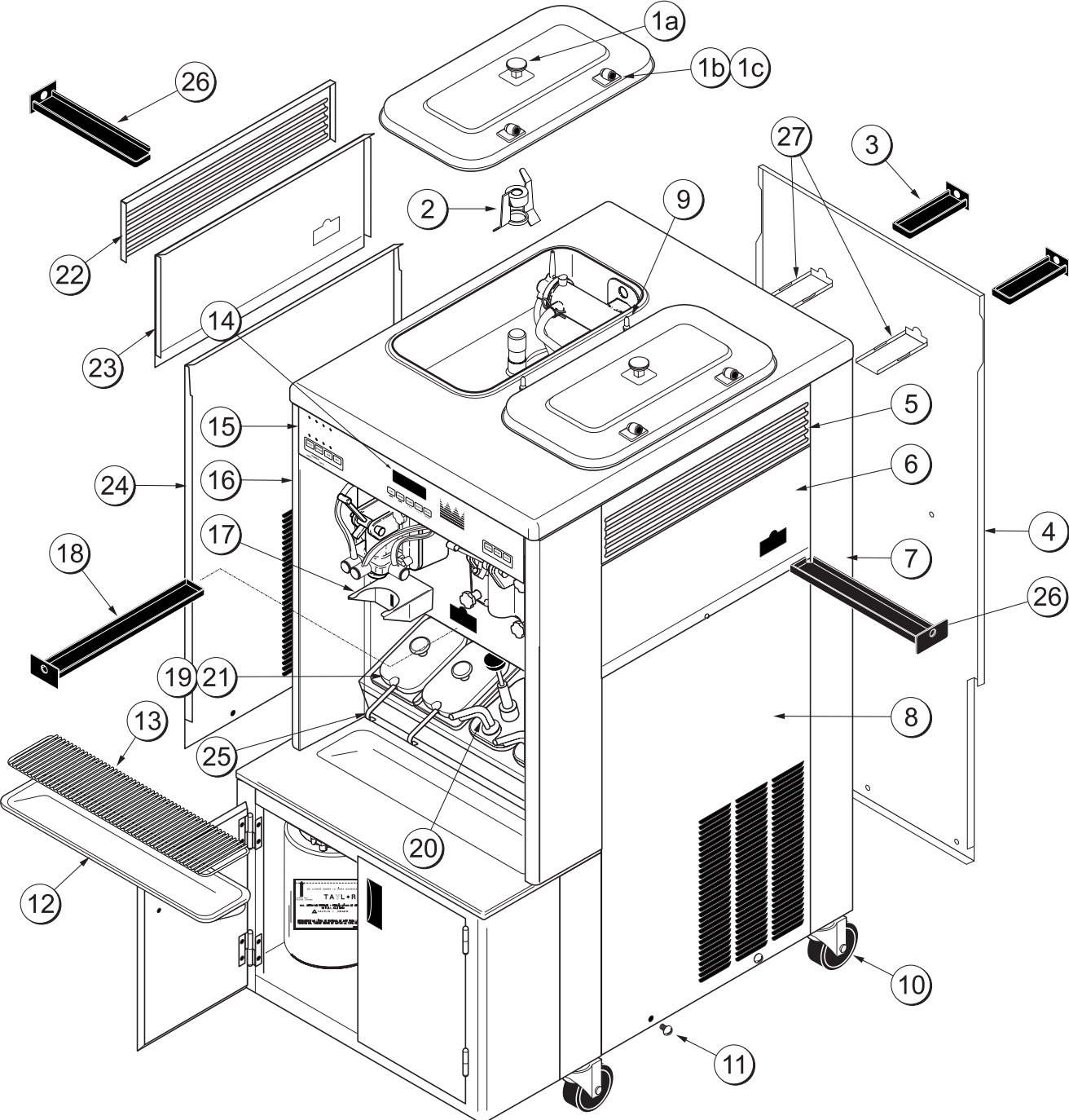

PH90 Exploded View Parts Identification

ITEM	DESCRIPTION	PART NO.
1	COVER A.-HOPPER	X42628-SER
1a	KNOB-MIX COVER	025429
1b	RETAINER-HOPPER COVER	042619
1c	SCREW-8-32 X 1/2 OVAL HD	043295
2	AGITATOR	X44797
3	PAN-DRIP HEAT TREAT	048204
4	PANEL-REAR	048208
5	LOUVER-SIDE-RIGHT	013631
6	PANEL-UPPER SIDE RIGHT	051632
7	TRIM-REAR CORNER RIGHT	044053
8	PANEL A.-SIDE LOWER R	X46450-SER
9	PIN-RETAINING-HOPPER CVR	043934
10	CASTER-SWV-3/4-10 ST. 4IN	044106
11	SCREW-1/4-20X3/8 RHM-SS	011694
12	TRAY-DRIP	028542
13	SHIELD-SPLASH	028548
14	DISPLAY-LIQUID CRYSTAL	X38062-SER
15	DECAL-DEC-TAYLOR	052282

ITEM	DESCRIPTION	PART NO.
16	PANEL A.-FRONT	X51576
17	HOLDER-CUP-SHAKE 3.906"	046939
18	PAN-DRIP 19-1/2 LONG	035034
19	JAR-SYRUP PLASTIC	036573
20	JAR-SYRUP STAINLESS	036574
21	LID-SYRUP JAR	042706
22	LOUVER-SIDE-LEFT	028288
23	PANEL SIDE UPPER LEFT	051631
24	PANEL A.-SIDE LEFT	X46449-SER
25	LADLE-1 FL. OZ. (30 ML.)	033637-1
26	PAN-DRIP 13-1/4 LONG	051642
*	FASTENER-CLIP 1/4-20 U	045865
*	CLIP-SPRING-CUP HOLDER	046940
*	TRIM-REAR CORNER LEFT	044051
*	GUIDE A.-DRIP PAN	X44041
*	GUIDE A.-DRIP PAN-RIGHT	X51625
*	GUIDE A.-DRIP PAN-LEFT	X51628
*	GUIDE A.-DRIP PAN-MIX PUMP (REAR)	X48228

*NOT SHOWN

Beater Door Assembly - Shake Side

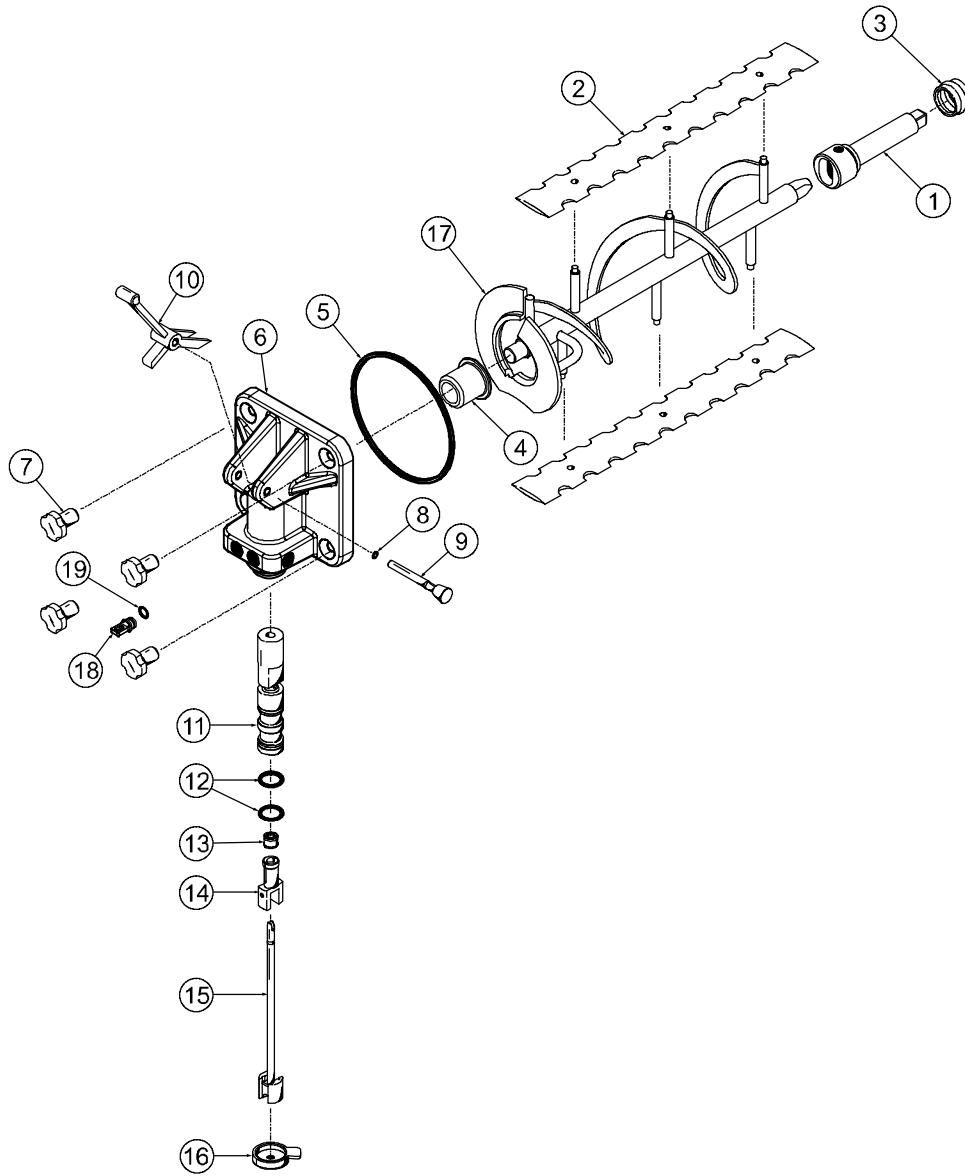

ITEM	DESCRIPTION	PART NO.
1	SHAFT-BEATER-7 QT. FLUTE	050985
2	BLADE-SCRAPER	041103
3	SEAL-DRIVE SHAFT	032560
4	BEARING-DOOR-FRONT	055605
5	O-RING - FREEZER DOOR	033493
6	DOOR A.-1 SPT-4 FLV-HT	X55724-SER
7	HANDSCREW (STUD NUT)	034034
8	O-RING - PIVOT PIN	016272
9	PIN A.-PIVOT	X22820
10	HANDLE-DRAW VALVE	034003

ITEM	DESCRIPTION	PART NO.
11	VALVE A.-DRAW	X42210
12	O-RING - DRAW VALVE	020571
13	SEAL-SPINNER SHAFT	036053
14	SPINNER-DRIVEN	034054
15	BLADE A.-SPINNER	X41895
16	CAP-RESTRICTOR	033107
17	BEATER A.-SHAKE	X50958
18	PLUG-SYRUP HOLE	026278
19	O-RING	024278

Beater Door Assembly - Soft Serve Side

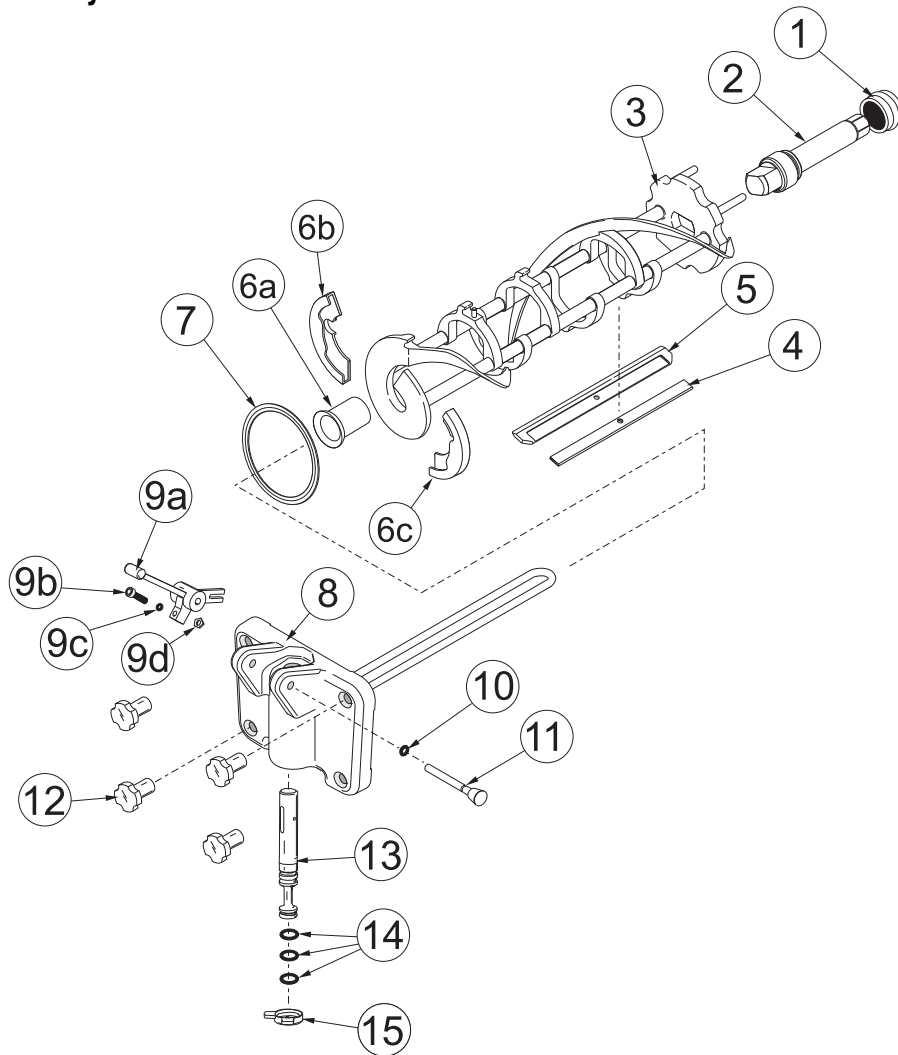

ITEM	DESCRIPTION	PART NO.
1	SEAL-DRIVE SHAFT	032560
2	DRIVE SHAFT	032564
3	BEATER A.	X46231
4	CLIP-SCRAPER BLADE	046236
5	SCRAPER BLADE	046235
*6a	BEARING-FRONT	050348
6b	SHOE-FRONT HELIX-REAR	050346
6c	SHOE-FRONT HELIX-FRONT	050347
7	GASKET-DOOR	048926
8	FREEZER DOOR A.	X51531-9
9	DRAW HANDLE-ADJ.	X44212

ITEM	DESCRIPTION	PART NO.
9a	DRAW HANDLE	044197
9b	SCREW-ADJUSTMENT	055092
9c	O-RING-ADJ. SCREW	015872
9d	NUT-5/16 -24 JAM	029639-BLK
10	O-RING-PIVOT PIN	016272
11	PIVOT PIN A.	X22820
12	HAND SCREW (STUD NUT)	021508
13	DRAW VALVE A.	X33582
14	O-RING-DRAW VALVE	014402
15	DESIGN CAP	014218

*USED W/FRONT HELIX SHOES 050346 & 050347 (KIT X50350)

Air/Mix Pump - Shake Side & Soft Serve Sides

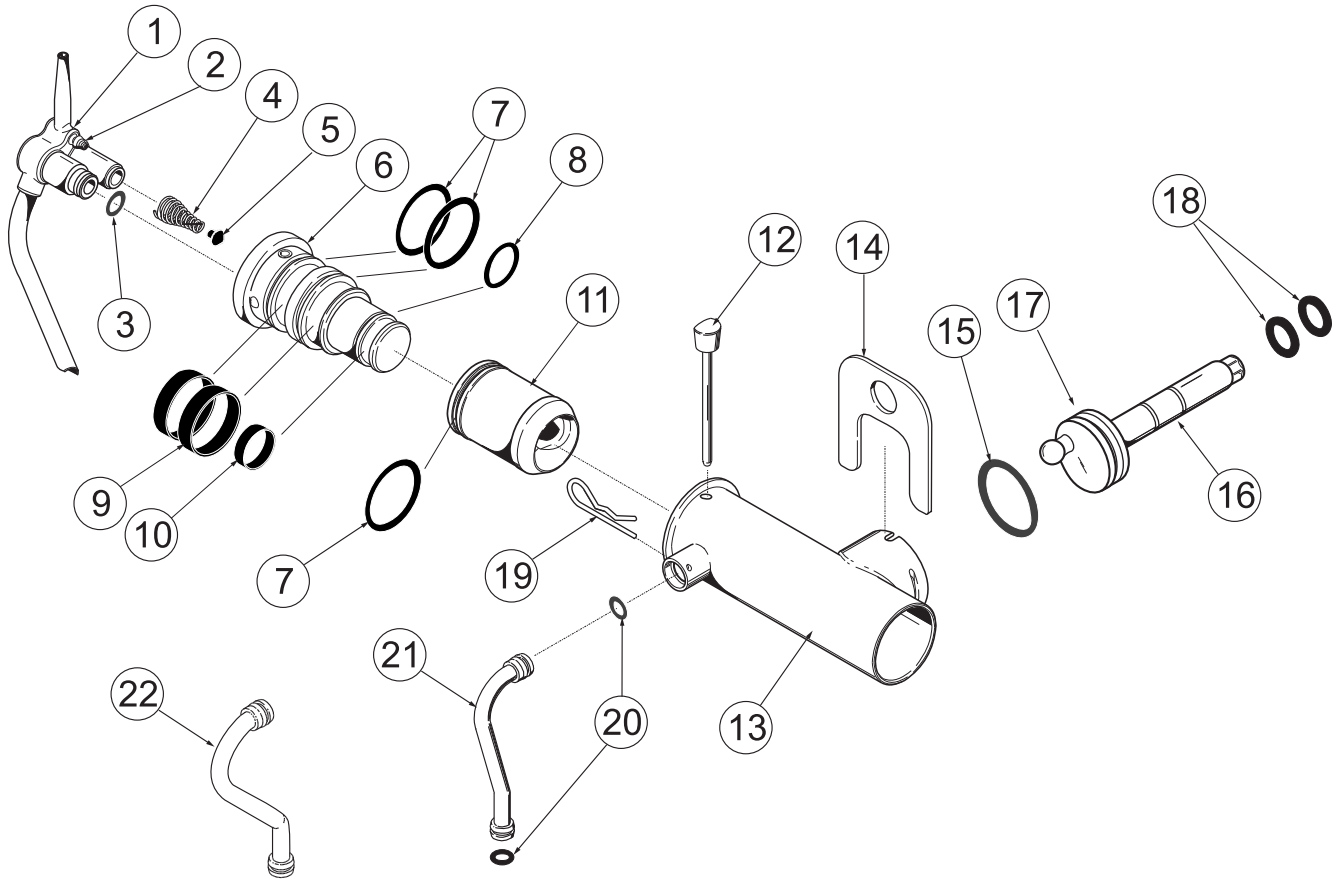

ITEM	DESCRIPTION	PART NO.
1 - 13	PUMP A.-COAX-SHAKE	X45788-A
	PUMP A.-COAX-SOFT SRV	X45316-B
1	TUBE A.-MIX INLET	X45318
2	SEAL-AIR INLET FITTING	045327
3	O-RING-MIX INLET FITTING	015835
4	SPRING-TAPERED	022456
5	POPPET-RUBBER	022473
6	BODY A.-COAX VALVE *A* SHAKE	X46859-A
	BODY A.-COAX VALVE *B* SOFT SERVE	X46860-B
7	O-RING-2-1/8 OD	020051
8	O-RING 1-3/8 OD	018664
9	RING-CHECK 2" OD X 1/2	020050
10	RING-CHECK 1-1/4 OD X 3/8	033215
11	PISTON-PUMP-SHAKE	032733
	PISTON-PUMP-SOFT SERVE	045319-B

ITEM	DESCRIPTION	PART NO.
12	PIN A.-COAX PUMP	X36950
13	CYLINDER A.-PUMP-SHAKE	X44669
	CYLINDER A.-PUMP-SOFT SV	X44755
14	CLIP-MIX PUMP RETAINER	044641
15	O-RING 1-3/4	008904
16	SHAFT-DRIVE	041948
17	CRANK-DRIVE	039235
18	O-RING-DRIVE SHAFT	048632
19	PIN-COTTER	044731
20	O-RING-MIX FEED TUBE-RED	016132
21	TUBE A.-PUMP FEED (SOFT SERVE)	X44666
22	TUBE A.-PUMP FEED (SHAKE)	X44615

Pump A.-Syrup-Heated X53800-BRN/TAN

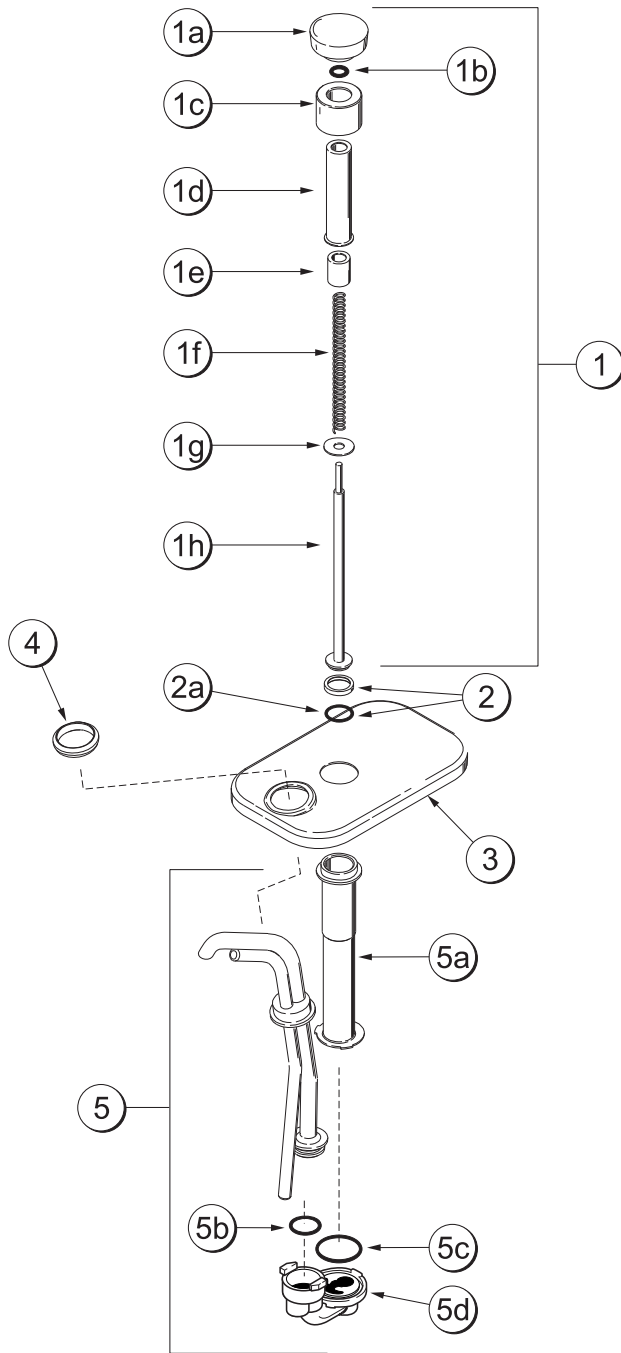

ITEM	DESCRIPTION	PART NO.
1	PLUNGER A.-PUMP	X36576-BRN
	PLUNGER A.-PUMP	X36576-TAN
1a	KNOB-PLUNGER-BROWN	032762-BRN
	KNOB-PLUNGER-TAN	032762-TAN
1b	O-RING 9/16 OD	016369
1c	NUT-PLUNGER	036577
1d	TUBE-PLUNGER	032757
1e	INSERT-PLUNGER	032758
1f	SPRING-PLUNGER	032761
1g	WASHER-NYLON	032760
1h	PLUNGER	036578
2	SEAL ASSEMBLY	X33057
2a	O-RING-13/16 OD X .103	019330
3	LID-PUMP	036579
4	NUT-LOCK	039680
5	PUMP A.-SYRUP HEATED	X53798-SER
5a	CLYINDER-SYRUP PUMP	051065
5b	O-RING 1 ID X .103 W	048148
5c	O-RING 1-5/16 OD X .103	048149
5d	BODY A.-PUMP VALVE	054084
	JAR-SYRUP-PLASTIC	036573
	JAR-SYRUP-STAINLESS	036574
NOTE: X53800-BRN/TAN REPLACES X42803-BRN/TAN & X48140-BRN/TAN		

Syrup Tank

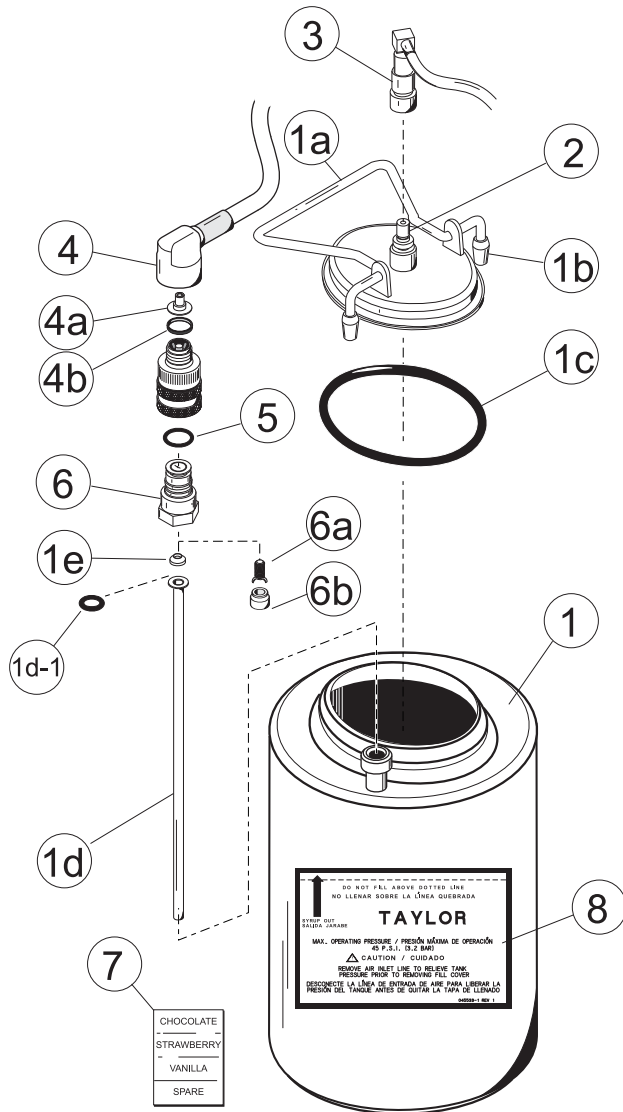

ITEM	DESCRIPTION	PART NO.
1	SYRUP TANK (4 QT./3.8 LITER)	045533
1a	SYRUP TANK COVER	035759-1
*1b	TIP-NYLON-WHITE	042747
	TIP-NYLON-GREY	024261
1c	GASKET-SYRUP TANK COVER	016037
1d	DIP TUBE	015441-7
1d-1	O-RING-DIP TUBE	018550
1e	WASHER	018595
2	CO2 QUICK DISCONNECT PLUG	021077
3	QUICK DISCONNECT SOCKET	021524
4	QUICK DISCONNECT SOCKET	021026
**4a	RESTRICTOR-SYRUP	030917
4b	GASKET-RUBBER	023551
5	O-RING-SYRUP QD PLUG	016030
6	SYRUP LINE QD PLUG	021081
6a	VALVE A.-QD PLUG	021081-2
6b	INSERT	021081-1
7	SET (4)-SYRUP FLAVOR DECALS	021523
8	DECAL-SYRUP TANK	045533-1

*DUAL SUPPLIER - ORDER AS NEEDED

**NOT USED ON CHOCOLATE

Accessories

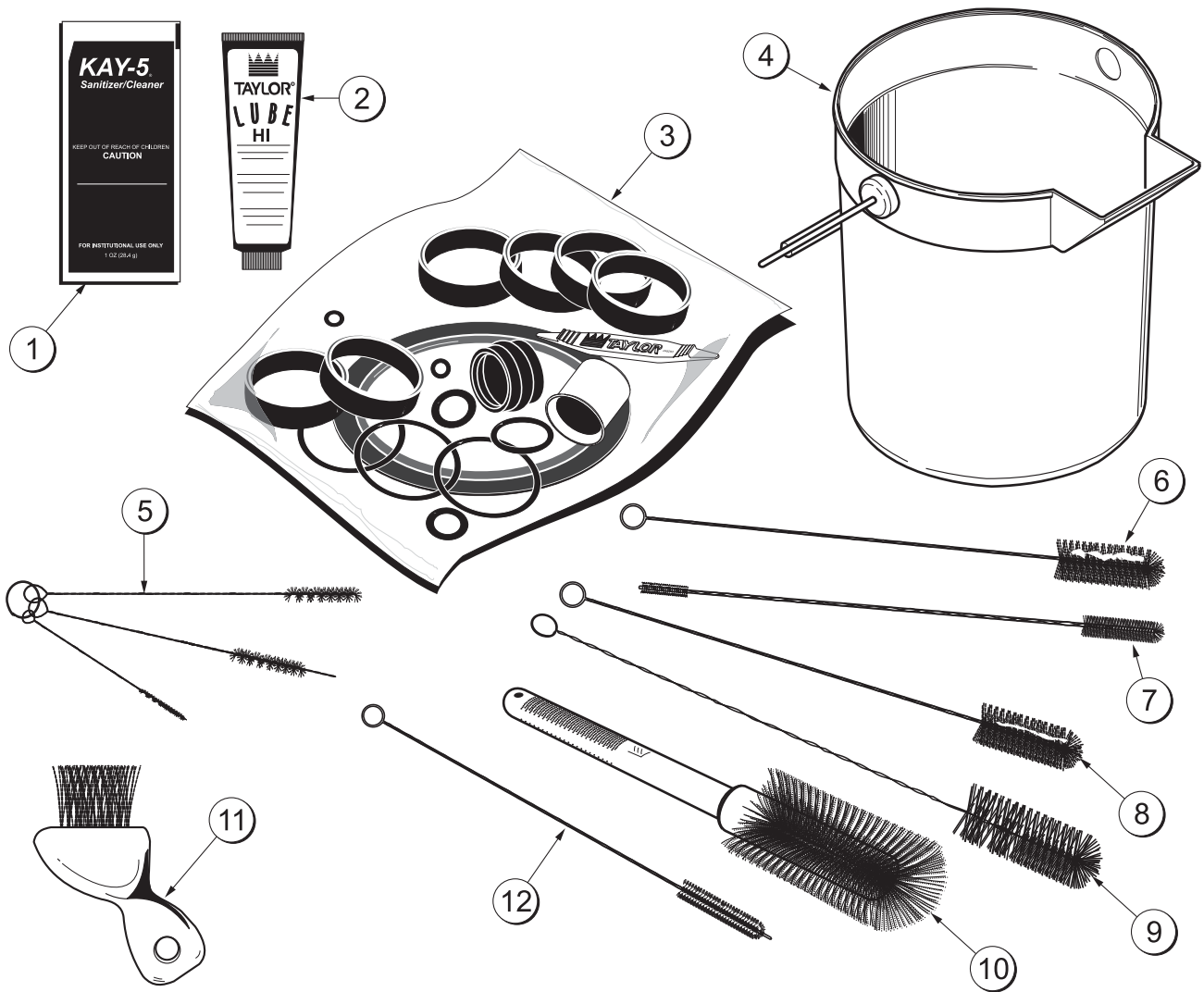

ITEM	DESCRIPTION	PART NO.
1	SANITIZER KAY-5 (125 PACKS)	041082
2	LUBRICANT-TAYLOR HI-PERF.	048232
3	KIT - TUNE UP	X49463-12
4	PAIL-MIX 10 QT.	013163
5	BRUSH-SET LVB	050103
6	BRUSH-REAR BRG 1 IN.DX2 IN	013071
7	BRUSH-DOUBLE ENDED	013072

ITEM	DESCRIPTION	PART NO.
8	BRUSH-DRAW VALVE 1"ODX2"	013073
9	BRUSH-DRAW VALVE 1-1/2"OD	014753
10	BRUSH-MIX PUMP BODY-3"X7"	023316
11	BRUSH-END-DOOR-SPOUT-SS	039719
12	BRUSH-1/2 IN. DIA.	033059
*	SANITIZER-STERA-SHEEN	010425

*NOT SHOWN

Section 5

Important: To the Operator

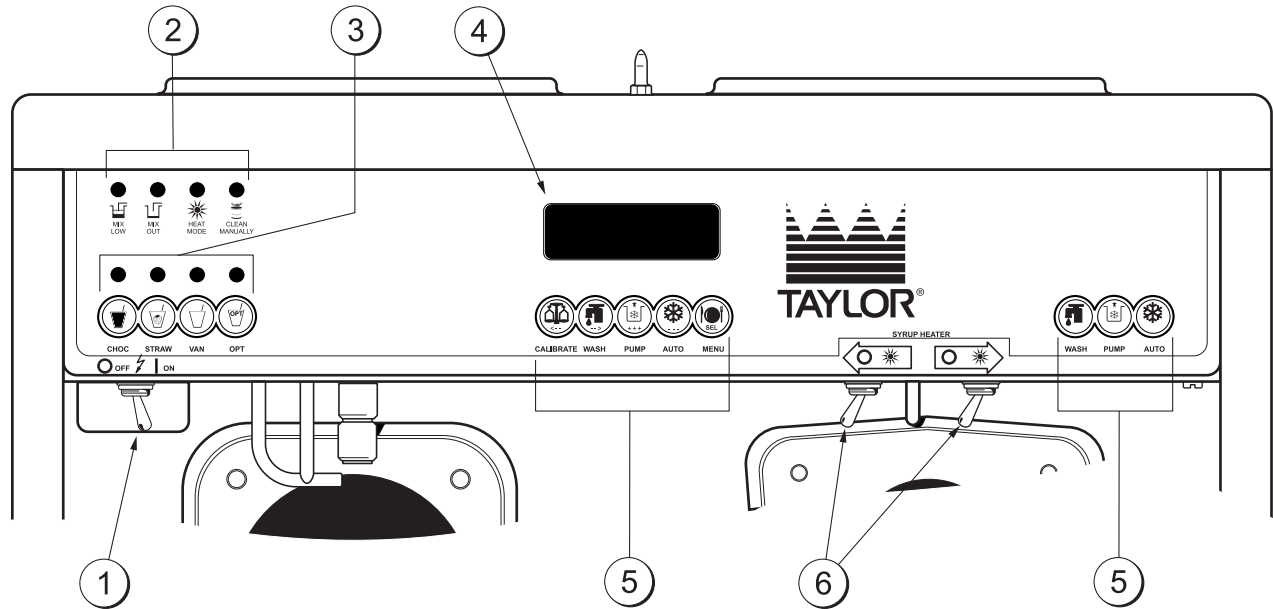

ITEM	DESCRIPTION
1	Power Switch (Toggle)
2	Indicator Lights (PCB A.-LED)
3	Flavor Selector Keypad (Switch-Membrane)
4	Liquid Crystal Display
5	Keypads (Switch-Membrane)
6	Heater Switches (Toggle)

Symbol Definitions

To better communicate in the International arena, the words on many of our operator switches and buttons have symbols to indicate their functions. Your Taylor equipment is designed with these International symbols.

The following chart identifies the symbol definitions.

= OFF

= ON

= CALIBRATE

= WASH

= PUMP

= AUTO

= MENU

= MIX LOW

= MIX OUT

= HEAT MODE

= CLEAN MANUALLY/BRUSH CLEAN

= CHOCOLATE

= STRAWBERRY

= VANILLA

= OPTIONAL

Power Switch

The power switch is located under the control panel on the left hand side of the unit. When placed in the ON position, the power switch allows Softech panel operation.

Indicator Lights

Mix Low – When the MIX LOW light begins to flash, it indicates the mix hopper has a low supply of mix and should be refilled as soon as possible. The word “LOW” will also display on the LCD indicator next to the word “MIX”.

Mix Out – When the MIX OUT light begins to flash, it indicates the mix hopper has been almost completely exhausted and has an insufficient supply of mix to operate the freezer. The word “OUT” will also display on the LCD indicator next to the word “MIX”. At this time the AUTO mode is locked out and the freezer will be placed in the STANDBY mode. To initiate the refrigeration system, add mix to the mix hopper and press the AUTO keypad. The freezer will automatically begin operation.

Heat Mode – When the HEAT MODE light is flashing, it indicates that the freezer is in the process of a heat cycle.

Clean Manually – When the CLEAN MANUALLY light is flashing, it indicates that the machine must be disassembled and brush cleaned within 24 hours.

When all four indicator lights are flashing, this signifies a locked condition. When MIX LOW and MIX OUT lights are flashing only, this signifies an unlocked condition.

Flavor Selector Keypad

Four shake flavors are offered from the Model PH90 freezer: chocolate, strawberry, vanilla (unflavored product), and an optional flavor. Press the desired shake flavor keypad and open the draw valve. Product and syrup will automatically blend to produce the chosen flavor.

Liquid Crystal Display

Located on the front control panel is the Liquid Crystal Display (LCD). The LCD is used to show what mode of operation the freezer is in and whether or not there is sufficient mix.

Heater Switch

The heater switch is located under the control panel on the right hand side of the unit. When placed in the ON position, the heater switch controls power to the heated syrup topping rail.

Reset Mechanism

The reset buttons are located in the syrup compartment, behind the syrup tanks. There is one for each side of the freezer.

The reset mechanism protects the beater motor from an overload condition. Should an overload occur, the reset mechanism will trip. To properly reset the freezer, place the power switch in the OFF position. Press the reset button firmly. Turn the power switch to the ON position. Clear the fault. Press the WASH keypad and observe the freezer’s performance. Open the side access panel to check if the beater motor is turning the drive shaft in a clockwise (from the operator end) direction without binding.



Do not use metal objects to press the reset button. Failure to follow this instruction may result in electrocution.

If it is turning properly, press the WASH keypad to cancel the cycle. Press the AUTO keypad on both sides of the machine to resume normal operation. If the freezer shuts down again, contact service technician.

Adjustable Draw Handle

The soft serve side of the freezer features an adjustable draw handle to provide the best portion control, giving a better, consistent quality to your product and controlling costs. The draw handle should be adjusted to provide a flow rate of 5 to 7-1/2 oz. of product by weight per 10 seconds. To INCREASE the flow rate, turn the screw COUNTERCLOCKWISE, and CLOCKWISE to DECREASE the flow rate. In addition, for purposes of SANITIZING and RINSING, the flow rate can be increased by removing the pivot pin and placing the restrictive bar on the TOP. When drawing product, **always** have the restrictive bar on the BOTTOM.



IMPORTANT: Once the draw rate is set, tighten the lock nut with a wrench.

Operating Screen Descriptions

When the machine is powered the system will initialize. The screen will display "INITIALIZING". There will be four types of data the system will check: LANGUAGE, SYSTEM DATA, CONFIG DATA, and LOCKOUT DATA. During the INITIALIZING... LANGUAGE screen, the alarm will be on. If the system data, configuration data, or lockout history data has become corrupt, the following screen will alert the operator that the system settings may have been changed.

**NVRAM FAULT
RESET TO DEFAULTS
PRESS SEL KEY**

Once the system has initialized the SAFETY TIMEOUT screen is displayed and the alarm is turned on.

**SAFETY TIMEOUT
ANY KEY ABORTS**

This screen will be displayed, with the alarm on, for 60 seconds or until any keypad is pressed.

After the safety timeout has been completed, and the power switch is OFF, one of the following screens is displayed.

The first screen is displayed if the machine is not in a brush clean state. If any of the requirements for a brush clean have not been met, the time displayed will remain at 5:00 minutes. When all the requirements for a brush cleaning are met, and the five minutes expire, the screen will change to the second screen, which is the standard power switch OFF screen.

POWER SWITCH OFF		
OUT	TIME: 4:40	OUT
68.5	HOPPER	62.1
69.5	BARREL	67.7

POWER SWITCH OFF
- - - - -
UNIT CLEANED

When the power switch is set in the ON position, the system mode of operation screen is displayed. In this example, the machine is ON, but no mode of operation has been selected. The second line of the display indicates whether there is a sufficient supply of mix in the hopper or if there is a LOW or OUT mix condition. The third line of the display shows the temperature of the mix hopper. After pressing the AUTO keypad, the last line of the display shows the month and date (MM = month, DD = day) that the machine needs to be disassembled and brush cleaned.

OFF	:MODE:	OFF
OK	:MIX:	OK
40.0F	HOPPER	40.0F
BRUSH CLEAN ON:	MM/DD	

This display indicates the freezer is operating in 3 different modes. The following information is given:

The left side of the freezer is operating in the STANDBY mode, and the mix level in the hopper is OUT. The right side is operating in the WASH and PUMP modes, and the mix level in the hopper is LOW. The temperature of the mix in both hoppers is 40°F. (4.4°C.), and the machine needs to be brush cleaned on October 31st.

STANDBY	:MODE:	WSH-PMP
OUT	:MIX:	LOW
40.0F	HOPPER	40.0F
BRUSH CLEAN ON:	10/31	

The following displays pertain to the HEAT cycle:

While in the heating phase, you will see this display. It shows the present temperature of the hopper.

HEAT	:MODE:	HEAT
HEAT	:PHASE:	HEAT
140.0F	HOPPER	140.0F
BRUSH CLEAN ON:	MM/DD	



DO NOT draw product or attempt to disassemble the unit during the HEAT cycle. The product is hot and under extreme pressure.

The mix temperature must be raised above 151°F. (66.1°C.) within 90 minutes or the freezer will be locked in STANDBY, and the cycle failure display will appear.

In the example, the hopper temperature is 140°F. (60°C.). The phase shows that the machine is in the HEAT phase of the treatment cycle.

When the heating phase is complete, the freezer goes into the holding phase of the cycle. The holding phase will hold the temperature above 151°F. (66.1°C.) for a minimum of 30 minutes.

In this example, the hopper temperature is 151°F. (66.1°C.).

HEAT	:MODE:	HEAT
HOLD	:PHASE:	HOLD
151.0F	HOPPER	151.0F
BRUSH CLEAN ON:	MM/DD	

The final phase of the heat treatment cycle is the cooling phase. Now the freezer must cool the mix below 41°F. (5°C.). If the product fails to cool in 2 hours, the freezer will lock out.

This example illustrates that the temperature is being lowered, but has not yet reached the set point.

HEAT	:MODE:	HEAT
COOL	:PHASE:	COOL
55.0F	HOPPER	55.0F
BRUSH CLEAN ON:	MM/DD	

When the entire heat cycle has been completed, the normal display will appear, showing the machine in the STANDBY mode. The machine may now be placed in AUTO or left in STANDBY.

STANDBY	:MODE:	STANDBY
OK	:MIX:	OK
41.0F	HOPPER	41.0F
BRUSH CLEAN ON:	MM/DD	

Hard Lock: There are two causes for a hard lock:

1. Fourteen days have elapsed since the last brush cleaning. The following screen will be displayed.

14 DAY TIMEOUT CLEANING REQ'D FREEZER LOCKED PRESS SEL KEY

2. There has been a thermistor failure (freezing cylinder, hopper, or glycol) during the heat treatment process.

SYSTEM FAULT SERVICE REQ'D FREEZER LOCKED PRESS SEL KEY
--

All four LED's on the front of the freezer will light. Press the SEL keypad.

The next display is the screen which will appear after the failure message. To comply with health codes, heat treatment system freezers **must** complete a heat treatment cycle daily, and **must** also be brushed cleaned every 14 days. Brush cleaning is the normal disassembly and cleaning procedure. Failure to follow these guidelines will cause the control to lock the freezer out of the AUTO mode. Press the WASH keypad.

**NO AUTO OPERATION
ALLOWED UNTIL
BRUSH CLEANING
PRESS WASH KEY**

The next display is the screen which will appear after the brush cleaning message and illustrates that the control is in the OFF mode and the machine needs to be disassembled and brush cleaned.

Once the unit is unlocked, only the mix out and mix low LED's will light.

OFF	:MODE:	OFF
OK	:MIX:	OK
41.0F	HOPPER	41.0F
	FREEZER LOCKED	

Soft Lock: If a heat treatment cycle has not been **initiated** within the last 24 hours, all four LED's on the front of the machine will light and a message will appear on the LCD. Line 3 of the LCD will indicate the reason the message appears. Following are the variable messages which will appear on line 3:

1. POWER SWITCH OFF: Power switch was in the OFF position.
2. MIX OUT PRESENT: There was mix out condition present.
3. AUTO OR STANDBY OFF: The unit was not in the AUTO or STANDBY mode.
4. NO HEAT CYCLE TRIED: A heat treatment cycle was not attempted in the last 24 hours. (AUTO HEAT TIME was advanced, or a power loss was experienced at the time the cycle was to occur, or a heat cycle failure not due to a thermistor failure.)

**NO HEAT TREAT START
BECAUSE
VARIABLE MESSAGE
PRESS SEL KEY**

If the following screen appears, a soft lock has occurred **during** the heat treatment cycle.

**HEAT TREAT CYCLE
FAILURE
FREEZER LOCKED
PRESS SEL KEY**

If the temperature of the product has not fallen below 41 °F (5 °C) by the end of the COOL cycle, the following screen will appear.

**PRODUCT OVER TEMP
FREEZER LOCKED
PRESS SEL KEY**

Press the SEL keypad to advance to the next display.

When one of these messages appears, automatic freezer operation cannot take place until the freezer is disassembled and brush cleaned or has completed a heat treatment cycle. The next display will instruct the operator to start a heat treatment cycle manually (by pressing the AUTO keypad), or to disassemble and brush clean the freezer. If the AUTO keypad is pressed, the freezer will automatically start the heat treatment cycle and only the heat cycle LED will light.

**NO AUTO OPERATION
ALLOWED. PRESS
AUTO FOR HEAT CYCLE
WASH TO BRUSH CLEAN**

If the WASH keypad is pressed, the next display will appear and the freezer will have to be disassembled and brush cleaned.

OFF	:MODE:	OFF
OK	:MIX:	OK
41.0F	HOPPER	41.0F
FREEZER LOCKED		

Once the freezer is unlocked by starting a heat treatment cycle, only the heat cycle LED will light. If the freezer is unlocked by brush cleaning, the mix low and mix out LED's will light.

Operator Menu

The OPERATOR MENU is used to enter the operator function displays. To access the OPERATOR MENU, simply press the MENU keypad. The cursor will flash over the letter "A" indicating that this is screen "A". To select a different screen, use the arrow keypads and move the cursor to the desired screen selection and press the SEL keypad.

OPERATOR MENU		
A B C D E F G H I J		
EXIT FROM MENU		SEL
< - - - - - >		

Screen "B" is FAULT DESCRIPTION. The fault description will indicate if there is a fault with the freezer and the side of the freezer where the fault occurred. To clear the tone for any faults which have been corrected, press the left arrow keypad. To see if there is more than one fault per cylinder, press the SEL keypad. When the last fault is displayed, the control will return to the OPERATOR MENU. To return to the main screen, move the cursor to "A" and press the SEL keypad again. Listed below are the variable messages which will appear, along with the corrective action:

1. NO FAULT FOUND: There was no fault found in the freezer. Nothing will appear on the screen after this variable message appears.
2. BEATER OVERLOAD: Press the reset button firmly. Clear the tone.

3. HPCO COMPRESSOR: Place the power switch in the OFF position. Wait 5 minutes for the machine to cool. Place the power switch in the ON position. Clear the tone.
4. COMP ON TOO LONG: Place the power switch in the OFF position. Call service technician. Clear the tone.
5. HOPPER THERM BAD: Place the power switch in the OFF position. Call service technician.
6. BARREL THERM BAD: Place the power switch in the OFF position. Call service technician.
7. GLYCOL THERM BAD: Place the power switch in the OFF position. Call service technician.
8. HOPPER OVER TEMP: The hopper temperature has risen too high as follows. Clear the tone.
 - a. The hopper temperature reaches 41°F. (5°C.) or higher after a power failure.
 - b. The hopper temperature has not fallen below 41°F. (5°C.) by the end of the COOL phase in the heat cycle.
9. BARREL OVER TEMP: The barrel temperature has risen too high as follows. Clear the tone.
 - a. The barrel temperature reaches 41°F. (5°C.) or higher after a power failure.
 - b. The barrel temperature has not fallen below 41°F. (5°C.) by the end of the COOL phase in the heat cycle.
10. POWER FAILURE: This message will appear in the FAULT DESCRIPTION if a power failure has occurred. Clear the tone.

FAULT DESCRIPTION	
L: VARIABLE MESSAGE	
R: VARIABLE MESSAGE	
CLR	SEL

Screen “C” is SET CLOCK. This screen will display the current date and time. The date and time may only be changed after the freezer has been manually brush cleaned but before it has been placed in the AUTO mode. Move the cursor under the number you wish to change. Press the plus keypad to increase the number; press the minus keypad to decrease the number. When the desired time and date appears, press the SEL keypad once to return to the OPERATOR MENU.

```

SET CLOCK
10:21 AM    11/07/1999
--
<--- -->  +++          ---  SEL
    
```

If an illegal date is entered, the following screen will appear. The correct date must be entered before leaving this display.

```

SET CLOCK
10:34 AM    02/30/1999
--          INVALID DATE
<--- -->  +++          ---  SEL
    
```

Screen “D” is SYSTEM INFORMATION. The first screen will indicate the software version used in the unit.

```

SOFTWARE VERSION
PH90 Control UVC2
Version 2.00
SEL
    
```

Press the SEL keypad to view the second screen of the SYSTEM INFORMATION display. This screen will indicate the Bill of Material number and serial number for the unit. Press the SEL keypad once to return to the Operator Menu.

```

B.O.M.      PH9033B000
S/N         J0000000
SEL
    
```

Screen “E” is AUTO HEAT TIME. This screen is used to set the time of day in which the heat treatment cycle will start. Move the cursor under the number you wish to change. Press the plus keypad to increase the number; press the minus keypad to decrease the number. When the desired time appears, press the SEL keypad once to return to the OPERATOR MENU.

```

AUTO HEAT TIME
TIME: 12:00 AM
--
<--- -->  +++          ---  SEL
    
```

Screen “F” is CURRENT CONDITIONS. This screen gives the viscosity of the product and the hopper and barrel temperatures. The last line of the display is the compressor countdown safety timer. The safety timer prevents the compressor from running more than 11 minutes (other than during the cooling phase of the heat treatment cycle).

Press the SEL keypad once to view the SERVINGS COUNTER screen.

VISC	HOPPER	BARREL
0	38.5	28.5
0.0	38.5	18.0
TIME C	11:00	11:00

The SERVINGS COUNTER screen indicates the number of times the draw switch has closed (number of draws) since the last brush cleaning or since the last serving counter reset. A maximum of 32,767 draws can be recorded; an additional draw will cause the counter to restart at zero. Pressing the MENU keypad/SEL will return the display to the Operator Menu.

```

SERVINGS COUNTER
LEFT      RIGHT
12        15
SEL
    
```

Draws are counted during the AUTO mode of operation only.

Screen "G" is HEAT CYCLE DATA. The information from the previous heat treatment cycles can be obtained through this screen. The most recent heat treatment cycle data will be shown first; press the plus keypad to scroll through the remaining heat cycle displays. If a heat treatment cycle failure should occur, a 2 character message will appear on the second line of the screen. Press the SEL keypad once to return to the OPERATOR MENU.

Listed below are the variable messages which could appear:

- HT Failure in the heating phase.
- CL Failure in the cooling phase.
- TT Failure in meeting total heat treatment cycle time requirement.
- MO Mix out condition.
- OP Operator interruption.
- PF Power failure. (If a power failure occurs, but the heat treatment cycle does not fail, an asterisk (*) will appear on the third line of the display.)
- BO Beater overload.
- HO High pressure cut-out.
- TH Failed thermistor probe.
- PS Power switch placed in the OFF position.
- ML Mix Low Condition.
- 14 14 Day Timeout Occurred.
- RC Heat Cycle Record Cleared.

11/07	02:00	05:09	
HEAT	OVER	COOL	XX
01:09	00:45	01:14	
TEMP AT END	38.5		1

Pressing the left arrow keypad on any HEAT CYCLE DATA screen will cause the extended data screen to be displayed. This screen shows the hopper, barrel, and glycol temperatures, and the amount of time the freezer spent in the phases of the heat cycle when the heat cycle completed, or was terminated.

HOPPER	BARREL	GLYCOL
151.0	134.5	98.1
153.0	136.0	
PHASE TIME: 1:20		1

Screen "H" is the LOCKOUT HISTORY. This screen displays a history of the last 40 hard locks, soft locks, and brush clean dates. Page numbers are indicated in the upper right hand corner. Page 1 always contains the most recent failure. Press the PUMP keypad to cycle through the pages.

The second line of the screen displays the date and time a failure occurs. The third line indicates the reason for a failure, or will indicate a successful brush cleaning has occurred. Some failures occur for multiple reasons. When this occurs, a page will be generated for each reason. Press the SEL keypad once to return to the Operator Menu, or twice to return to the Main Screen.

LOCKOUT HISTORY	1
11/21/99 02:08	
SOFTLOCK ABORT	
+++	SEL

Screen "I" is the SERVICE MENU. This screen can only be accessed by a service technician.

Screen "J" is the STANDBY MODE. To place the left side of the freezer in the STANDBY mode, move the cursor under the word "yes". Press the SEL keypad to execute the command and bring up the screen for the right side of the freezer. To place the right side of the freezer in the STANDBY mode, move the cursor under the word "yes". When the SEL keypad is pressed, the command will be executed. To exit the STANDBY mode and place the unit in AUTO, press the AUTO keypad once. Pressing the AUTO keypad again will place the unit in the OFF mode.

STANDBY MODE	YES	NO
LEFT		---
<--- -->		SEL

Section 6

Operating Procedures

Equipment Set Up

Evaluate the condition of lights and screen messages (Hard Lock or Soft Lock, etc.) before performing opening procedures. If all four LED's on the front of the unit are lit, the unit is locked. (See Figure 1.)

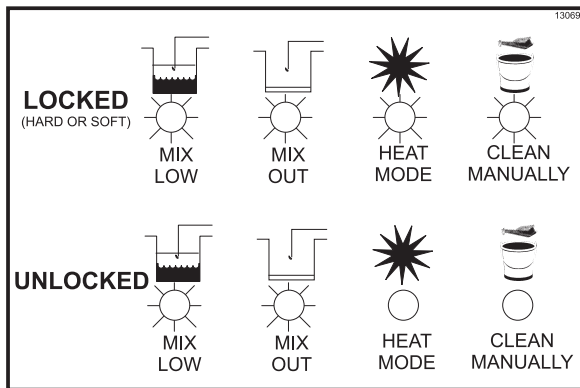

Figure 1

Note: When lubricating parts, use an approved food grade lubricant (example: Taylor Lube HP).

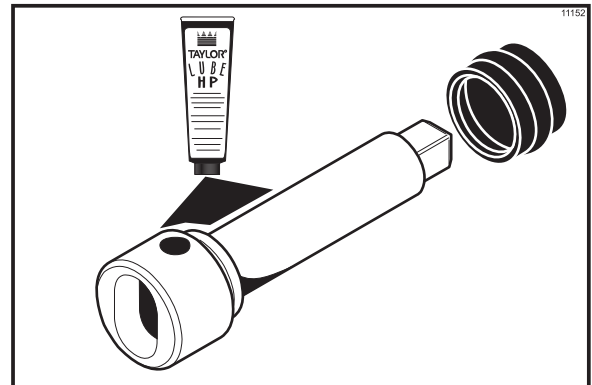

Figure 2

Freezing Cylinder Assembly - Shake Side



MAKE SURE POWER SWITCH IS IN THE "OFF" POSITION. Failure to do so may cause injury from hazardous moving parts, or electrocution.

Be certain your hands are sanitized before assembling the freezer.

With the parts tray available for the shake side:

Step 1

To install the drive shaft, lubricate the groove and shaft portion that comes in contact with the bearing on the beater drive shaft. Slide the seal over the shaft and groove until it snaps into place. **DO NOT** lubricate the square end of the drive shaft. Fill the inside portion of the seal with 1/4" more lubricant and evenly lubricate the end of the seal that fits onto the rear shell bearing. (See Figure 2.)

Install the drive shaft through the rear shell bearing in the freezing cylinder and engage the square end firmly into the gear box coupling. Be sure the drive shaft fits into the drive coupling without binding. (See Figure 3.)

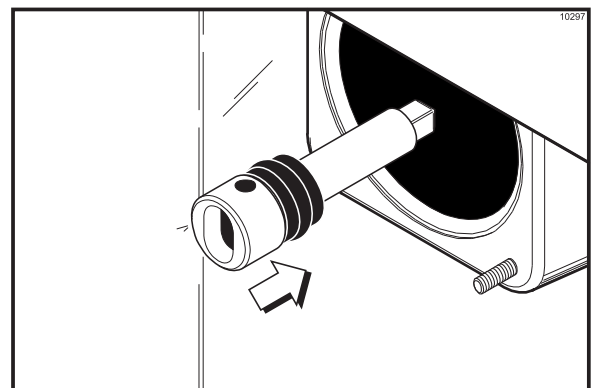

Figure 3

Check scraper blades for any nicks or signs of wear. If any nicks are present, replace the blades.

Note: Scraper blades should be replaced every 6 months.

If blades are in good condition, place each scraper blade over the holding pins on the beater assembly. (See Figure 4.)

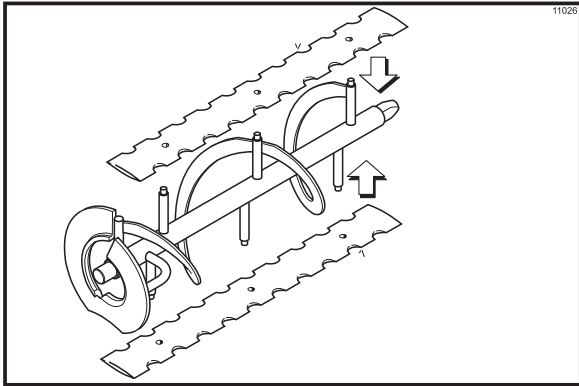

Figure 4

Note: The holes in the scraper blade must fit over the pins to prevent damage.

Holding the blades on the beater assembly, insert the drive shaft of the beater assembly through the rear shell bearing in the freezing cylinder and engage the square end firmly into the drive coupling. (See Figure 5.)

Note: When properly seated, the beater will not protrude beyond the front of the freezing cylinder.

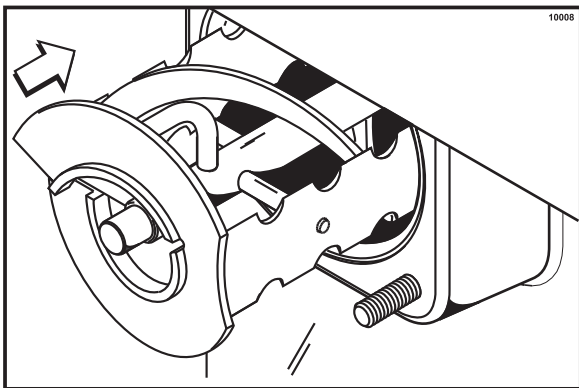

Figure 5

Step 2

Assemble the freezer door. Place the freezer door o-ring into the groove on the back of the freezer door. DO NOT lubricate the o-ring. Lubricate the outside diameter of the front bearing. Slide the front bearing into the door hub. (See Figure 6.)

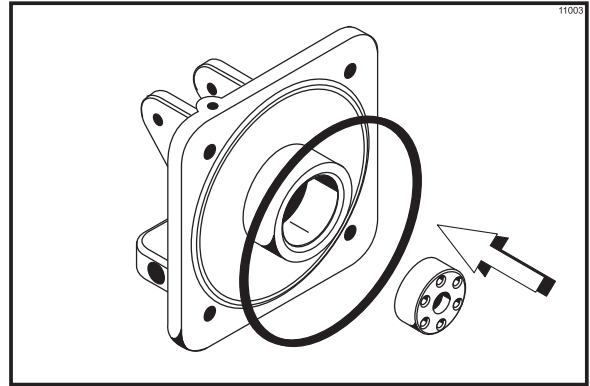

Figure 6

Step 3

Install the freezer door. Position the freezer door on the 4 studs on the front of the freezing cylinder. Install the handscrews. Tighten equally in a criss-cross pattern to insure the door is snug. **Do not over-tighten.** (See Figure 7.)

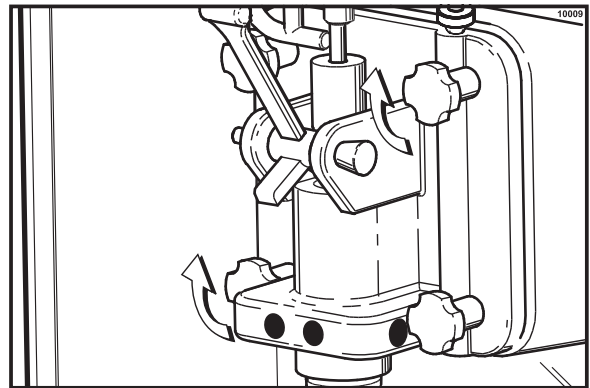

Figure 7

Step 4

Assemble the draw valve spinner assembly. Inspect draw valve o-rings for cuts or nicks. (Replace if cut or nicked.) If draw valve o-rings are in good condition, slide the two o-rings into the grooves of the draw valve and lubricate. (See Figure 8.)

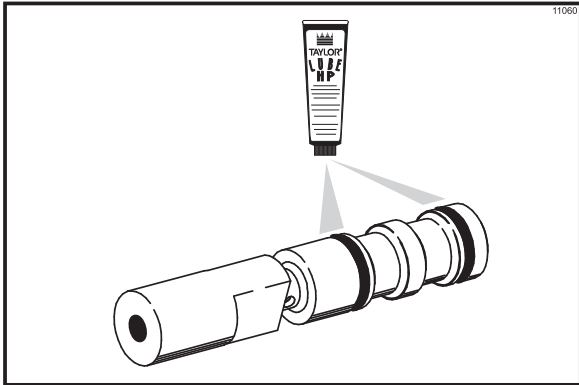

Figure 8

Lubricate the outer diameter of the spinner shaft seal. Fill the cups on each end of the seal with lubricant. Insert the spinner shaft seal into the bottom of the draw valve as far as it will go. The spinner shaft seal should fit into the seal groove located inside the draw valve cavity.

Important: Inspect to see that the spinner shaft seal is correctly installed in the groove. A worn, missing, or improperly installed spinner shaft seal will cause product leakage out the top of the draw valve. (See Figure 9.)

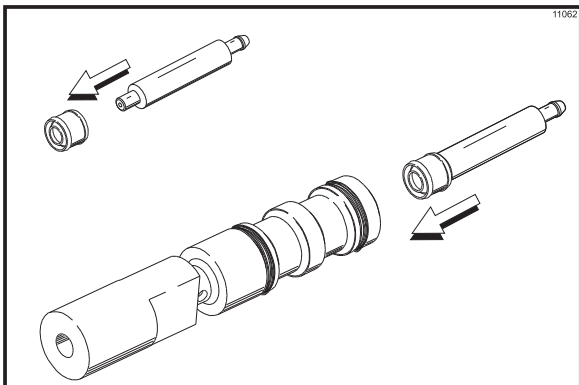

Figure 9

Place an even coat of lubricant on the smaller end of the driven spinner. (See Figure 10.)

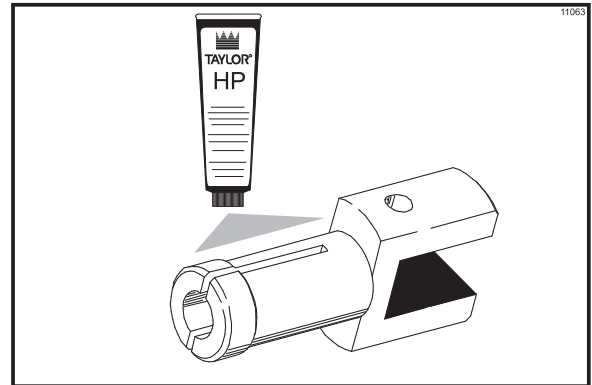

Figure 10

Squeezing the split end together, insert the driven spinner through the metal opening of the draw valve until it snaps into place. (See Figure 11.)

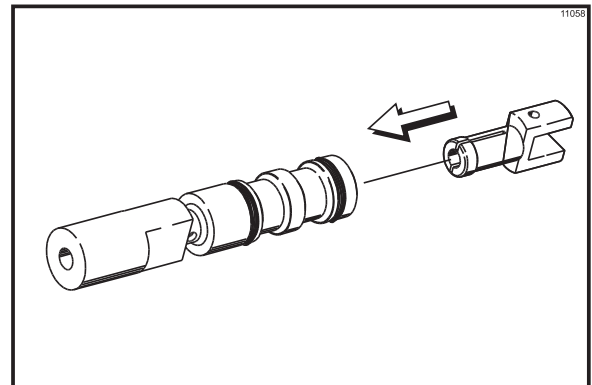

Figure 11

Step 5

Lubricate the inside of the freezer door spout, top and bottom. (See Figure 12.)

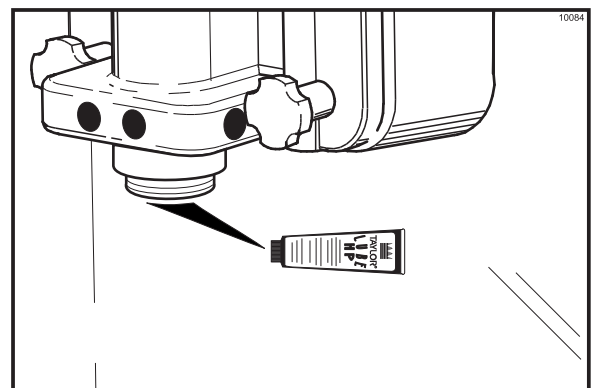

Figure 12

Install the draw valve spinner assembly. Insert the draw valve from the bottom until the slot in the draw valve which accepts the draw handle comes into view. (See Figure 13.)

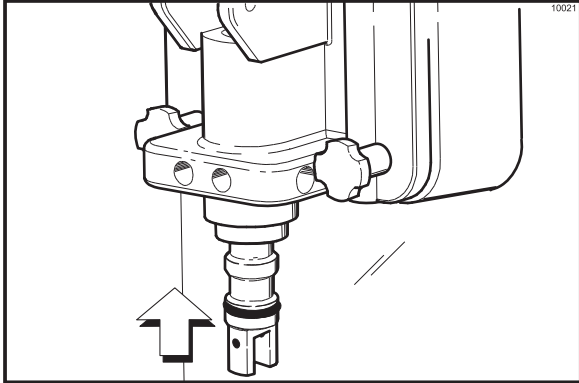

Figure 13

Install the draw handle. With the stopping tab of the draw handle facing down, slide the fork of the draw handle into the slot of the draw valve. Secure the draw handle with the pivot pin. (See Figure 15.)

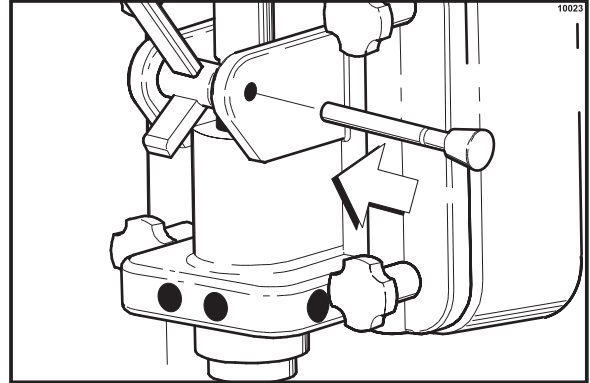

Figure 15

Step 6

Install and lubricate the pivot pin o-ring. (See Figure 14.)

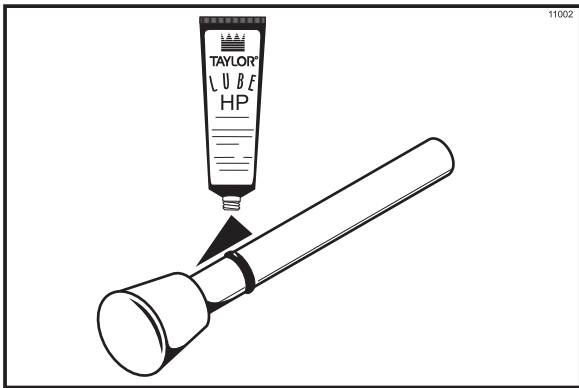

Figure 14

Step 7

Install the spinner blade. Lubricate the shaft of the spinner blade up to the groove. (See Figure 16.)

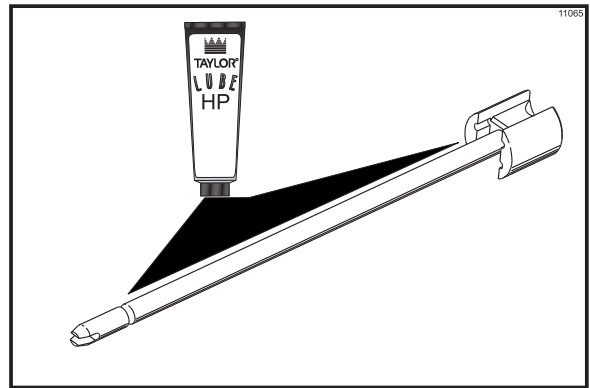

Figure 16

Insert the spinner blade shaft from the bottom, into the center of the driven spinner, and up through the draw valve cavity until the shaft appears at the top of the draw valve. The spinner blade must be aligned and engaged to the driven spinner at the bottom. This allows the spinner shaft to raise high enough to be engaged into the spinner coupling at the top. (See Figure 17.)

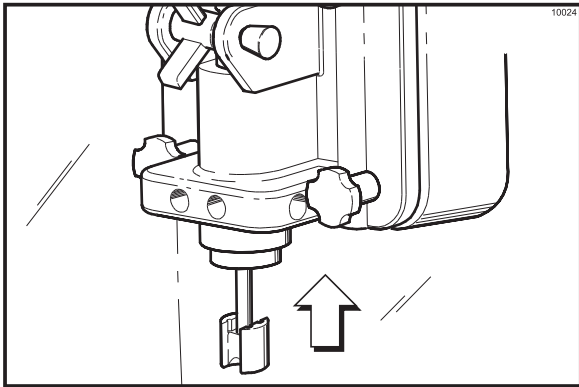

Figure 17

Raise the locking collar of the spinner coupling and insert the spinner shaft into the cavity of the coupling until the locking collar can drop into the locked position. (See Figure 18.)

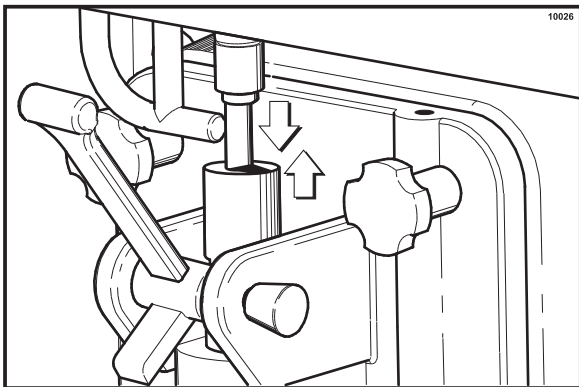

Figure 18

Step 8

Snap the restrictor cap over the end of the door spout. (See Figure 19.)

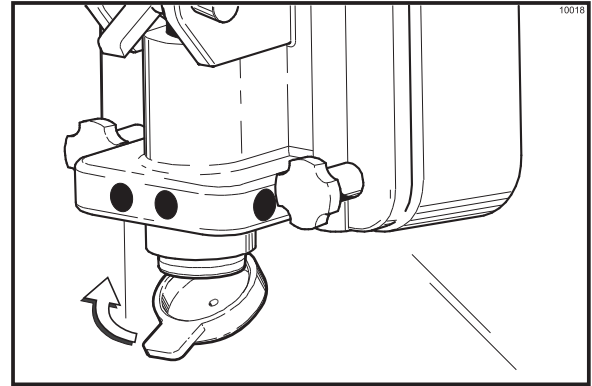

Figure 19

Freezing Cylinder Assembly - Soft Serve Side



MAKE SURE POWER SWITCH IS IN THE “OFF” POSITION. Failure to do so may cause injury from hazardous moving parts, or electrocution.

With the parts tray available for the soft serve side:

Step 1

Before installing the drive shaft, lubricate the groove on the drive shaft. Slide the drive shaft seal over the small end of the shaft and engage into the groove on the shaft. Heavily lubricate the inside portion of the seal and also lubricate the flat end of the seal that comes in contact with the rear shell bearing. Apply an even coat of lubricant to the shaft. **DO NOT** lubricate the hex end. (See Figure 20.)

Note: When lubricating parts, use an approved food grade lubricant (example: Taylor Lube Hi Performance).

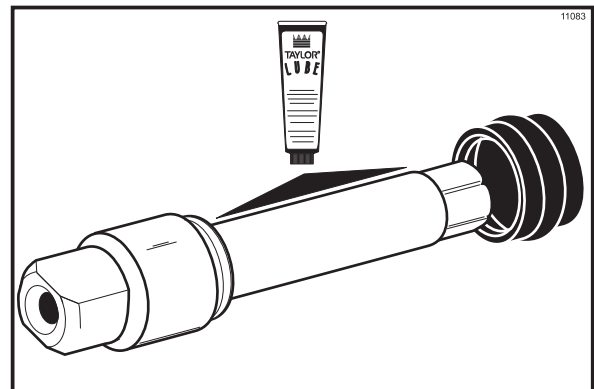

Figure 20

Insert the drive shaft through the rear shell bearing in the freezing cylinder and engage the hex end firmly into the drive coupling. (See Figure 21.)

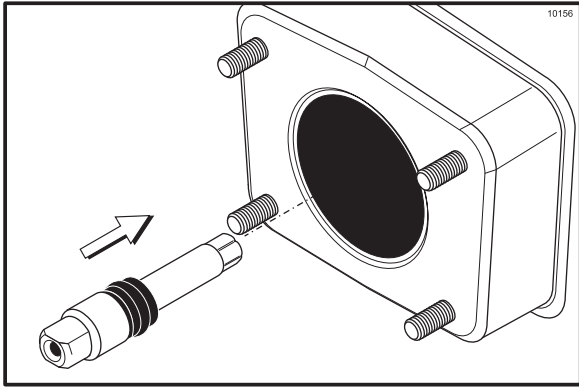

Figure 21

Step 2

Install the beater assembly. First check the scraper blades for any nicks or signs of wear. If any nicks are present, or if the blades are worn, replace both blades. If the blades are in good condition, install the scraper blade clips over the scraper blades. Place the rear scraper blade over the rear holding pin on the beater. (See Figure 22.)

Note: Scraper blades should be replaced every 3 months.

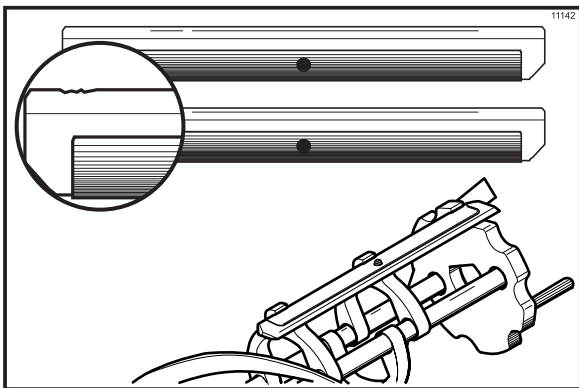

Figure 22

Note: The hole on the scraper blade must fit securely over the pin to prevent costly damage.

Holding the rear blade on the beater, slide it into the freezing cylinder halfway. Install the front scraper blade over the front holding pin. (See Figure 23.)

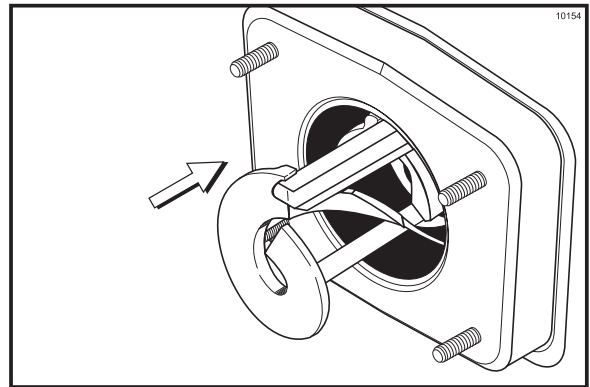

Figure 23

Install the beater shoes. (See Figure 24.)

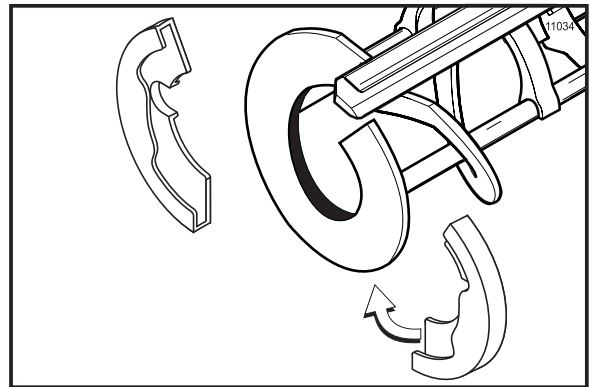

Figure 24

Slide the beater assembly the rest of the way into the freezing cylinder.

Make sure the beater assembly is in position over the drive shaft. Turn the beater slightly to be certain that the beater is properly seated. When in position, the beater will not protrude beyond the front of the freezing cylinder. (See Figure 25.)

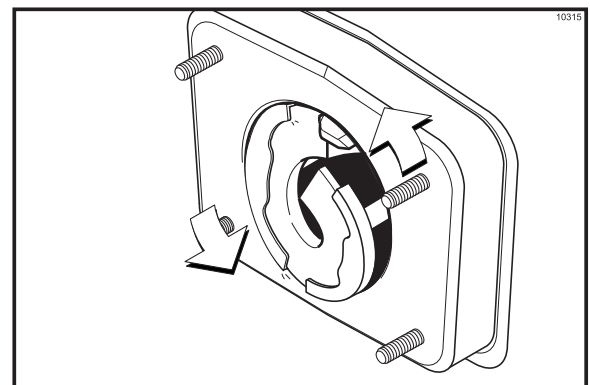

Figure 25

Step 2

Assemble the freezer door. Place the door gasket into the groove on the back of the freezer door. Slide the front bearing over the baffle rod so the flanged edge is against the door. DO NOT lubricate the gasket or bearing. (See Figure 26.)

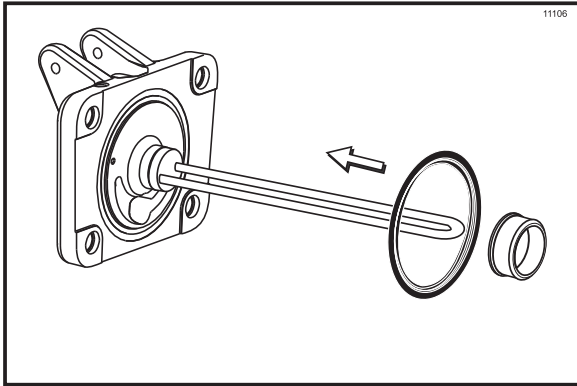

Figure 26

Step 3

Install the freezer door. Insert the baffle rod through the beater in the freezing cylinder. With the door seated on the freezer studs, install the handscrews. Tighten equally in a criss-cross pattern to insure the door is snug. (See Figure 27.)

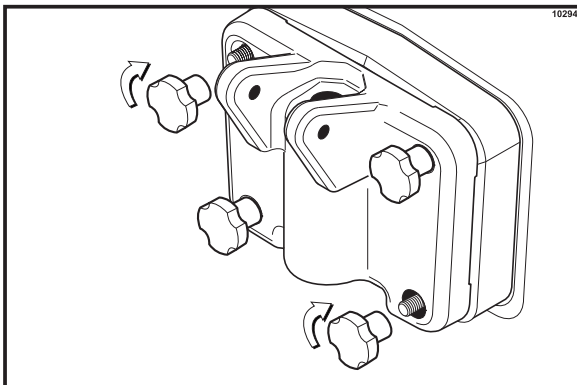

Figure 27

Step 4

Install the draw valve. Slide the 3 o-rings into the grooves on the draw valve and lubricate. (See Figure 28.)

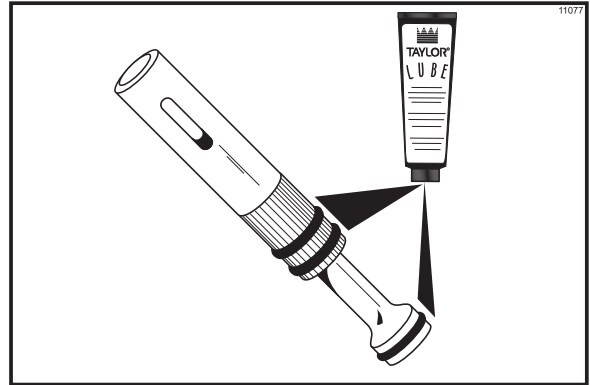

Figure 28

Lubricate the inside of the freezer door spout, top and bottom. (See Figure 29.)

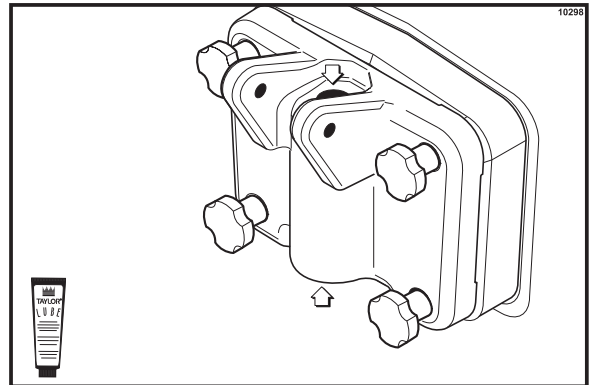

Figure 29

Insert the draw valve from the bottom until the slot in the draw valve comes into view. (See Figure 30.)

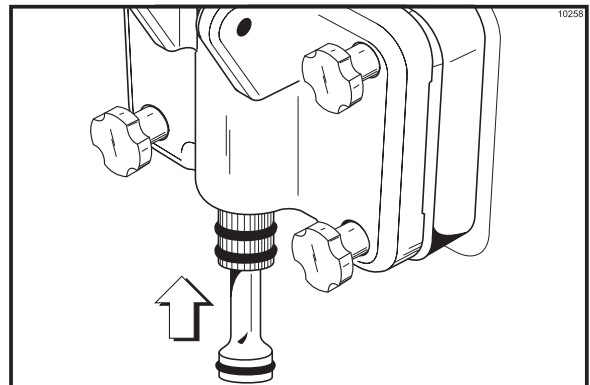

Figure 30

Step 5

Slide the o-ring into the groove on the pivot pin and lubricate. (See Figure 31.)

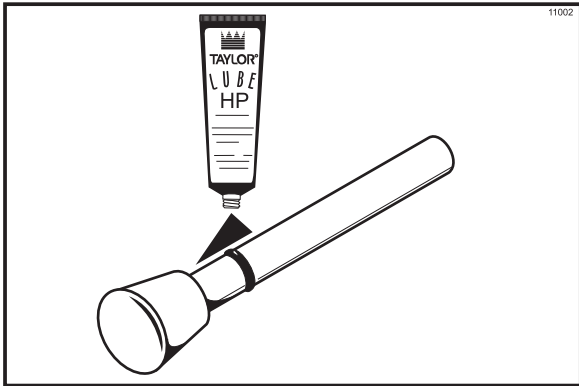

Figure 31

Install the draw handle. Slide the fork of the draw handle in the slot of the draw valve. Secure with pivot pin. (See Figure 32.)

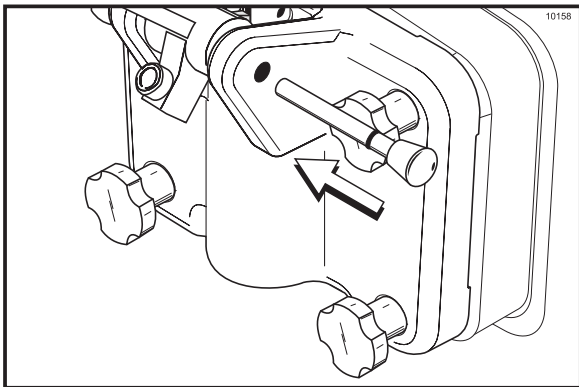

Figure 32

Note: The soft serve side features an adjustable draw handle to provide portion control, giving a better consistent quality to your product and controlling costs. The draw handle should be adjusted to provide a flow rate of 5 to 7-1/2 oz. (142 g. to 213 g.) of product by weight per 10 seconds. To INCREASE the flow rate, turn the adjustment screw COUNTER-CLOCK WISE and CLOCKWISE to DECREASE the flow rate.



IMPORTANT: Once the draw rate is set, tighten the lock nut with a wrench.

Step 6

Snap the design cap over the bottom of the door spout. (See Figure 33.)

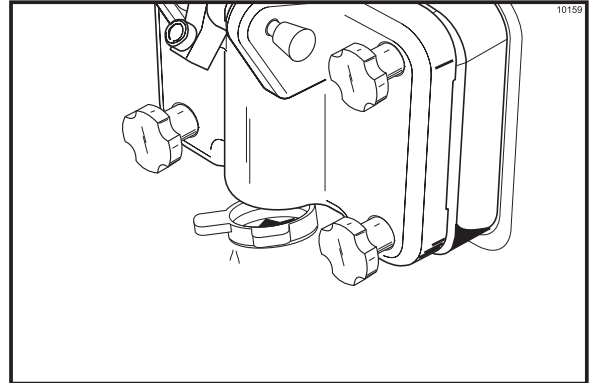

Figure 33

Step 7

Slide the long drip pan into the hole in the front panel above the syrup topping dispensers. (See Figure 34.) Slide the two shorter drip pans into the holes in the rear panel.

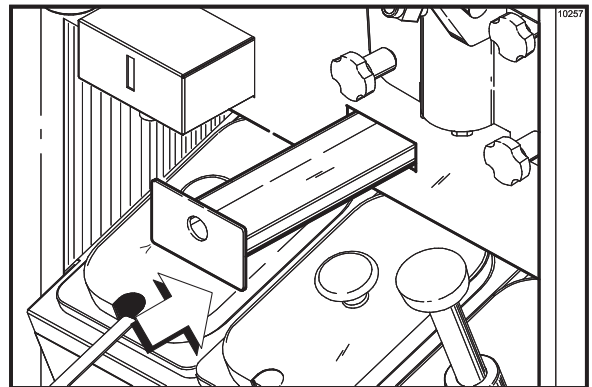

Figure 34

Install the two notched drip pans in the left and right side panels. (See Figure 35.)

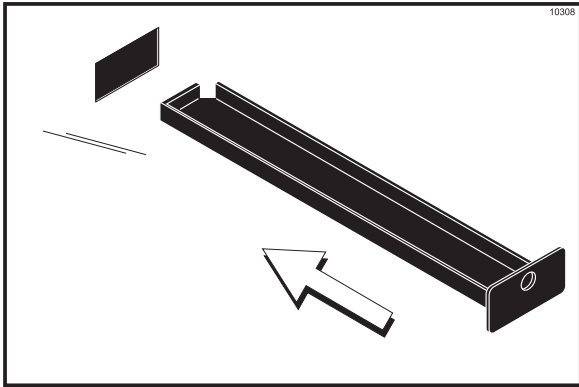

Figure 35

Step 8

Install the front drip tray and splash shield under the door spouts. (See Figure 36.)

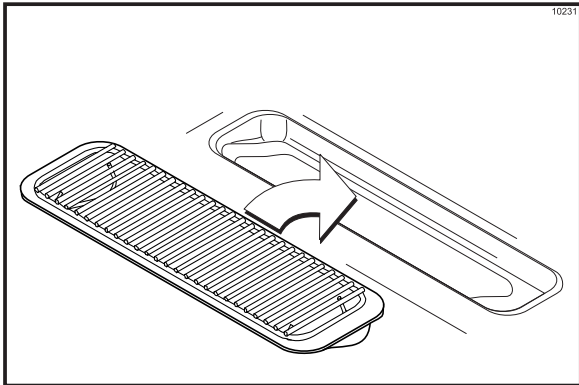

Figure 36

Mix Hopper Assembly

To assemble the mix hopper for both sides of the freezer, the steps will be the same. Therefore, first assemble the shake mix hopper, then go back and duplicate these procedures for the soft serve mix hopper.

With the parts trays available:

Step 1

Inspect the rubber pump parts. The check rings and o-rings must be in 100% good condition for the pump and entire unit to operate properly. Check rings and o-rings cannot properly serve their intended functions

if nicks, cuts, or holes in the material are present. The rubber poppet must also be in good condition.

Refer to page 75 for the normal replacement schedule. Replace any defective parts immediately and discard the old.

Step 2

Assemble the piston. Slide the o-ring into the groove of the piston. DO NOT lubricate this o-ring. (See Figure 37.)

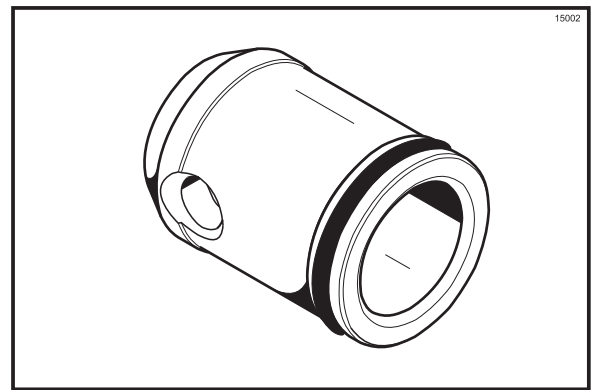

Figure 37

Step 3

Assemble the valve body. Slide two large and one small o-ring, and two large and one small check ring into their respective grooves on the valve body. (See Figure 38.)

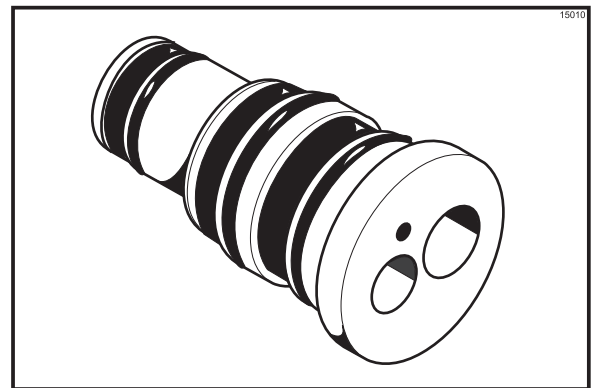

Figure 38

Note: Check rings have two smooth surfaces. A concave shape indicates an incorrect assembly. Turn the check ring inside out to correctly expose the flat surface. (See Figure 39.)

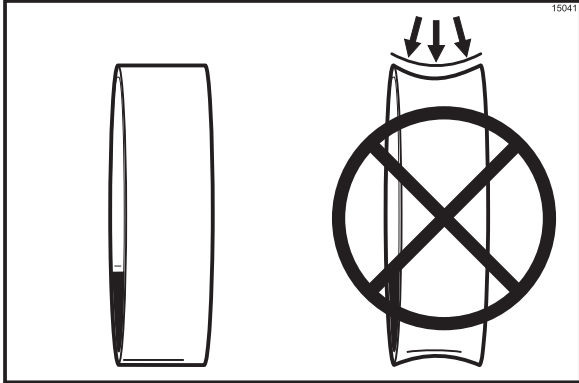

Figure 39

Step 4

Lightly lubricate the inside wall of the piston with a paper thin layer of lubricant (example: Taylor Lube Hi Performance). See Figure 40.)

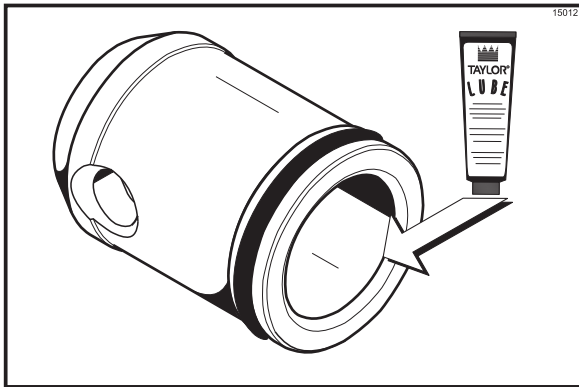

Figure 40

Insert the narrow end of the valve body into the open end of the piston. (See Figure 41.)

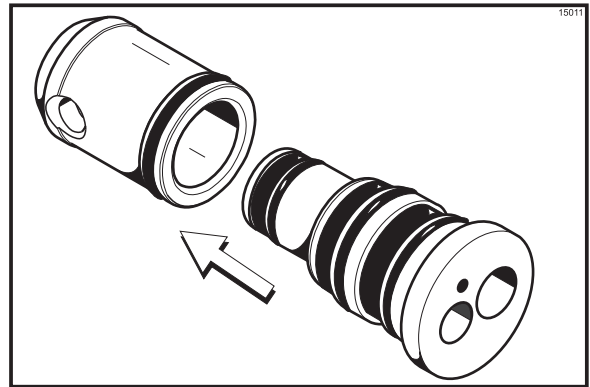

Figure 41

Step 5

Lightly lubricate the inside of the pump cylinder at the bottom with a paper thin layer of lubricant. (See Figure 42.)

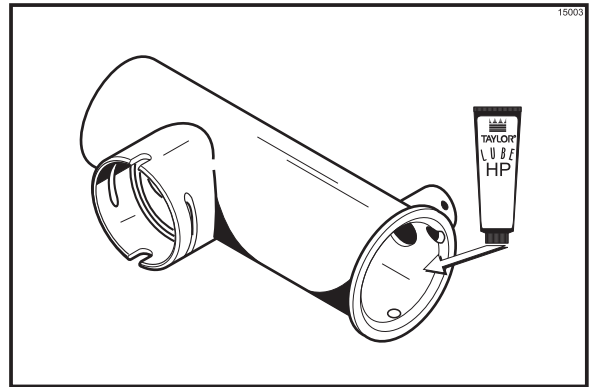

Figure 42

Insert the already assembled piston and valve body into the bottom of the pump cylinder. (See Figure 43.)

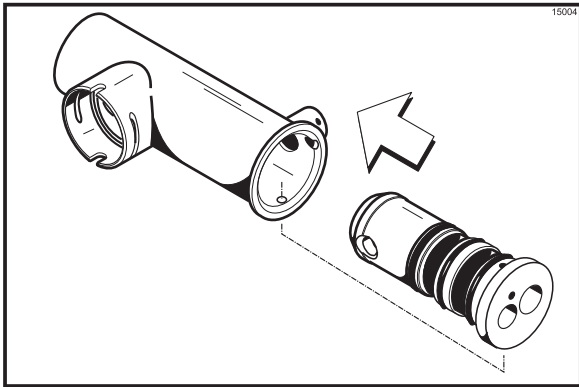

Figure 43

Note: The drive hole in the piston must be visible through the drive hole opening in the pump cylinder and the aligning ball located at the base of the valve body must be positioned into the notch at the bottom of the pump cylinder.

Step 6

Assemble the mix inlet tube assembly. Slide the o-ring and seal into the grooves on the fittings and thoroughly lubricate. (See Figure 44.)

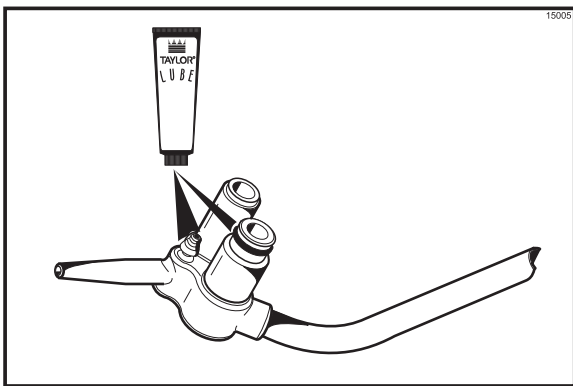

Figure 44

Attach the spring and poppet to the end of the pressure relief fitting. The spring must be securely fastened and not allowed to float freely.

Note: The spring and rubber poppet act as a pressure relief valve to prevent a pressure build up in the freezing cylinder. (See Figure 45.)

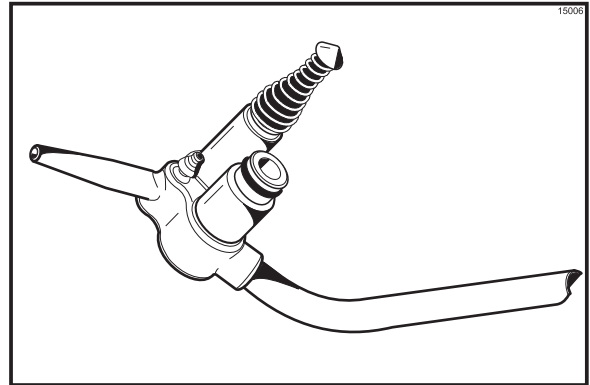

Figure 45

Step 7

Insert the mix inlet tube assembly into the hole in the base of the valve body. (See Figure 46.)

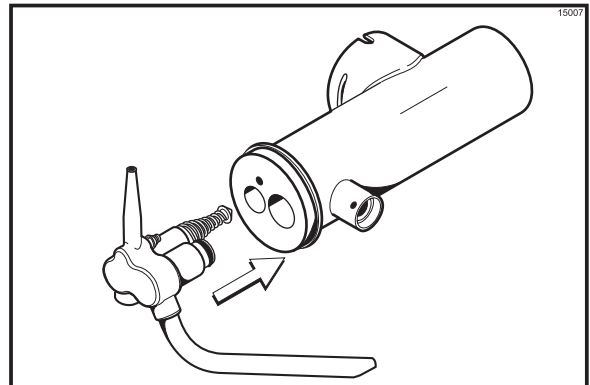

Figure 46

Secure the pump parts in position by sliding the retaining pin through the cross holes located at the bottom of the pump cylinder. (See Figure 47.)

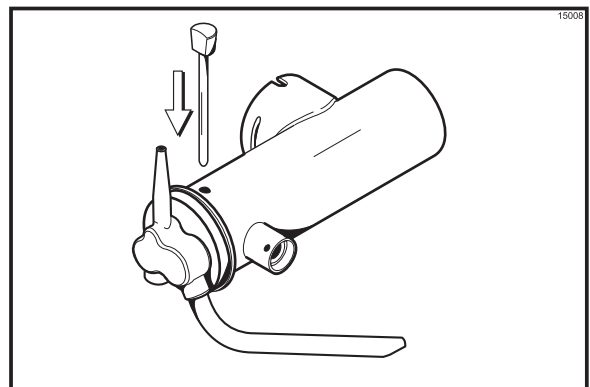

Figure 47

Note: The head of the retaining pin should be facing UP with the pump correctly installed.

Step 8

Install one o-ring on each end of the mix feed tube, and thoroughly lubricate. (See Figure 48.)

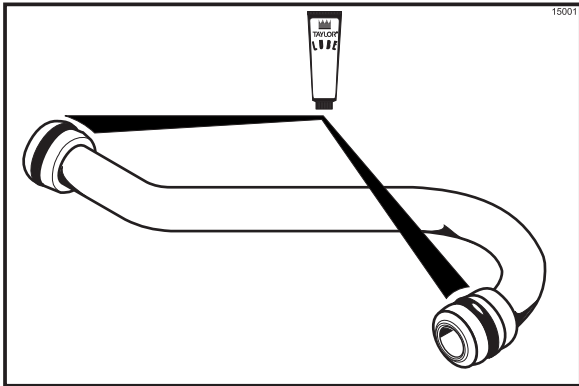

Figure 48

Step 9

Lay the pump assembly, pump clip, mix feed tube and cotter pin in the bottom of the mix hopper for sanitizing. Lay the agitator in the bottom of the mix hopper for sanitizing. (See Figure 49.)

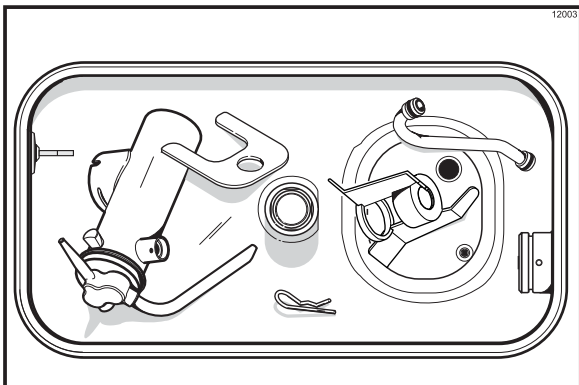

Figure 49

Step 10

Slide the large o-ring and two smaller o-rings into the grooves on the drive shaft. Thoroughly lubricate the o-rings and shaft. DO NOT lubricate the hex end of the shaft. (See Figure 50.)

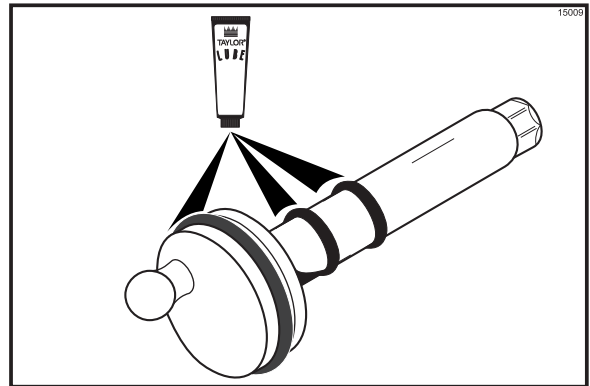

Figure 50

Install the hex end of the drive shaft into the drive hub at the rear wall of the mix hopper. (See Figure 51.)

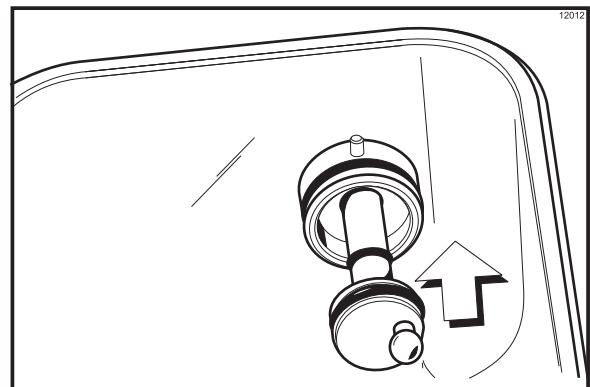

Figure 51

Note: For ease in installing the pump, position the ball crank of the drive shaft in the 3 o'clock position.

Sanitizing - Shake Side

Step 1

Prepare a pail of approved 100 PPM sanitizing solution (examples: 2-1/2 gal. [9.5 liters] of Kay-5® or 2 gal. [7.6 liters] of Stera-Sheen®). USE WARM WATER AND FOLLOW THE MANUFACTURER'S SPECIFICATIONS.

Step 2

Pour the sanitizing solution over all parts in the bottom of the mix hopper and allow it to flow into the freezing cylinder.

Note: You have just sanitized the mix hopper and parts; therefore, be sure your hands are clean and sanitized before going on in these instructions.

While the solution is flowing into the freezing cylinder, take particular care to brush clean the mix level sensing probes, the mix hopper, mix inlet hole, the outside of the agitator drive shaft housing, the agitator, the air/mix pump, pump clip, mix feed tube and cotter pin.

Step 3

Prepare two more pails of the sanitizing solution, per instructions in Step 1.

Step 4

Install the pump assembly at the rear of the mix hopper. To position the pump on the drive hub, align the drive hole in the piston with the drive crank of the drive shaft. Secure the pump in place by slipping the pump clip over the collar of the pump, making sure the clip fits into the grooves in the collar. (See Figure 52.)

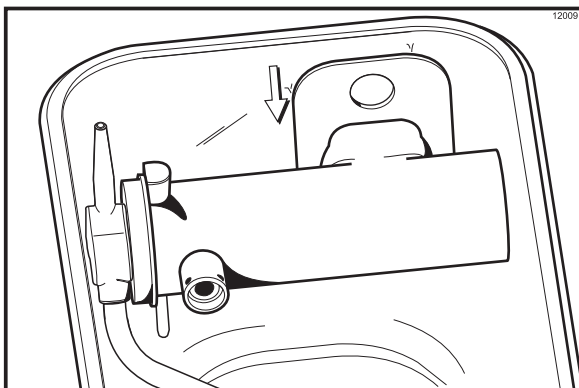

Figure 52

Step 5

Pour the sanitizing solution into the mix hopper. The sanitizing solution should be within 1" (25 mm) of the top of the hopper.

Step 6

Push one end of the vinyl sanitizing tube onto the air inlet tube for the pump. Be sure the free end is submerged in the sanitizing solution in the hopper. (See Figure 53.)

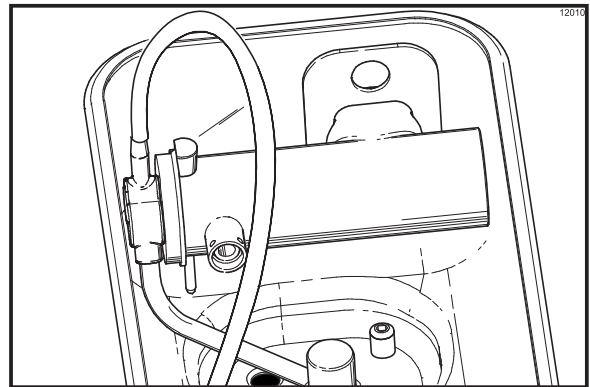

Figure 53

Step 7

Brush the exposed sides of the hopper. Wait at least five minutes before proceeding with these instructions.

Step 8

Place the power switch to the ON position.

Step 9

Press the WASH keypad. This will cause the sanitizing solution in the freezing cylinder to be agitated. (See Figure 54.)

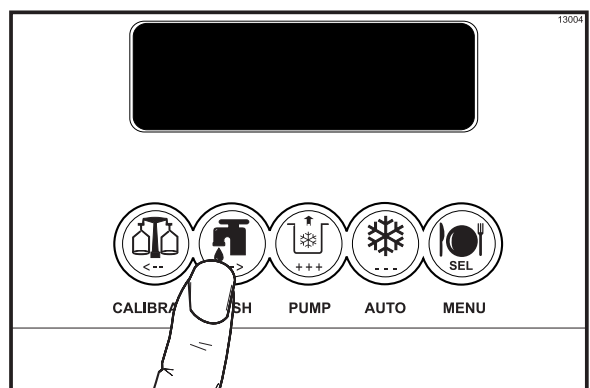

Figure 54

Step 10

With a pail beneath the door spout, open the draw valve and press the PUMP keypad. Open and close the draw valve six times.

Open the draw valve and draw off 2 quarts (1.9 liters) of sanitizing solution. Remove the vinyl sanitizing tube from the air/mix pump and draw off the remaining sanitizing solution.

Step 11

Press the WASH and PUMP keypads and close the draw valve. (See Figure 55.)

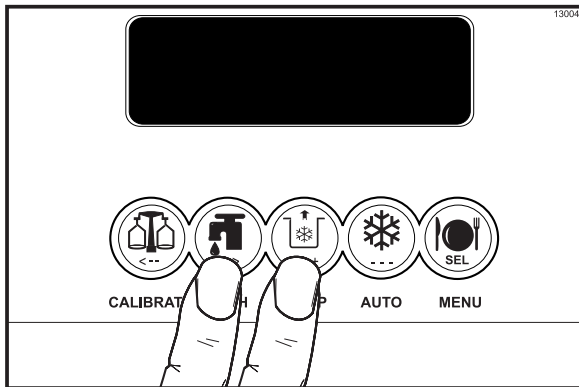

Figure 55

Note: Be sure your hands are clean and sanitized before going on in these instructions.

Step 12

Place the agitator on the agitator drive shaft housing. (See Figure 56.)

Note: To stop agitator movement, press the CAL keypad. The agitator will continue movement after 10 seconds have elapsed.

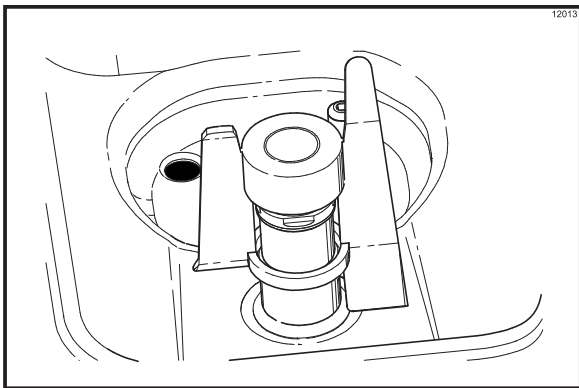

Figure 56

Note: If the agitator paddle should stop turning during normal operation, with **sanitized hands**, remove the agitator from the agitator drive shaft housing and brush clean with sanitizing solution. Install the agitator back onto the agitator drive shaft housing. Press the CAL keypad to stop rotation.

Step 13

Stand the mix feed tube in the corner of the mix hopper. Place the cotter pin in position in the outlet fitting of the pump.

Step 14

Remove the restrictor cap.

Step 15

Return to the freezer with a small amount of sanitizing solution. With a pail below the door spout, dip the door spout brush into the sanitizing solution and brush clean the syrup ports in the freezer door, door spout, bottom of the driven spinner and spinner blade, and syrup line fittings.

Note: To assure sanitary conditions are maintained, brush clean each item for a total of 60 seconds, repeatedly dipping the brush in sanitizing solution.

With the syrup port brush, brush each syrup port hole 10 to 15 times. Dip the brush in sanitizing solution before brushing each port.

Fill the squeeze bottle with sanitizing solution. With a pail beneath the door, insert the adapter end of the squeeze bottle into the syrup port, and squeeze the bottle firmly. This action will force solution out of the adjacent port and down around the spinner. This procedure should be performed for at least 10 seconds per port.

Install the restrictor cap.

Sanitizing - Soft Serve Side

Step 1

Prepare a pail of approved 100 PPM sanitizing solution (examples: 2-1/2 gal. [9.5 liters] of Kay-5® or 2 gal. [7.6 liters] of Stera-Sheen®). **USE WARM WATER AND FOLLOW THE MANUFACTURER'S SPECIFICATIONS.**

Step 2

Pour the sanitizing solution over all parts in the bottom of the mix hopper and allow it to flow into the freezing cylinder.

Note: You have just sanitized the mix hopper and parts; therefore, be sure your hands are clean and sanitized before going on in these instructions.

While the solution is flowing into the freezing cylinder, take particular care to brush clean the mix level sensing probes, the mix hopper, mix inlet hole, the outside of the agitator drive shaft housing, the agitator, the air/mix pump, pump clip, mix feed tube and cotter pin.

Step 3

Prepare one more pail of sanitizing solution, per instructions in Step 1.

Step 4

Install the pump assembly at the rear of the mix hopper. To position the pump on the drive hub, align the drive hole in the piston with the drive crank of the drive shaft. Secure the pump in place by slipping the pump clip over the collar of the pump, making sure the clip fits into the grooves in the collar. (See Figure 57.)

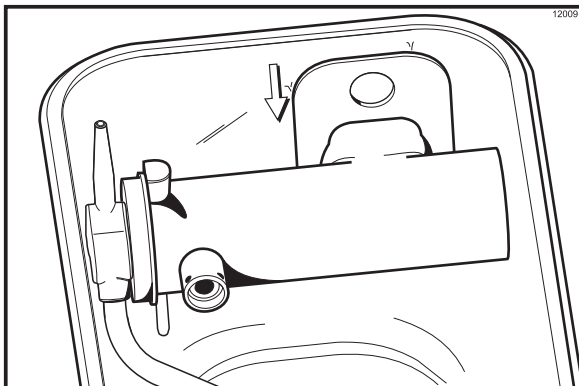

Figure 57

Step 5

Pour the 2 gallons (7.6 liters) of sanitizing solution into the mix hopper.

Step 6

Push one end of the vinyl sanitizing tube onto the air inlet tube for the pump. Be sure the free end is submerged in the sanitizing solution in the hopper. (See Figure 58.)

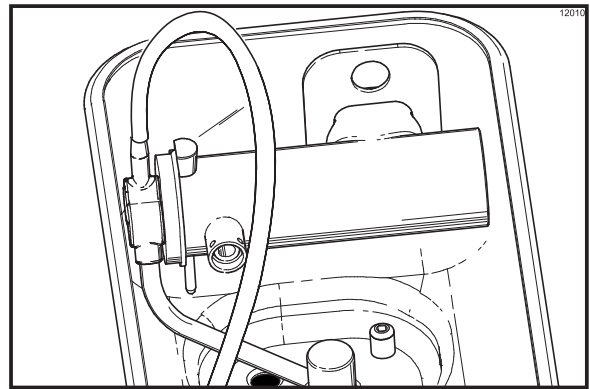

Figure 58

Step 7

Brush the exposed sides of the hopper. Wait at least 5 minutes before proceeding with these instructions.

Step 8

Press the WASH keypad. This will cause the sanitizing solution in the freezing cylinder to be agitated.

Step 9

With a pail beneath the door spout, open the draw valve and press the PUMP keypad. Open and close the draw valve 6 times.

Open the draw valve and draw off 2 quarts (1.9 liters) of sanitizing solution. Remove the vinyl sanitizing tube from the air/mix pump and draw off the remaining sanitizing solution.

Step 10

Press the WASH and PUMP keypads and close the draw valve. (See Figure 59.)

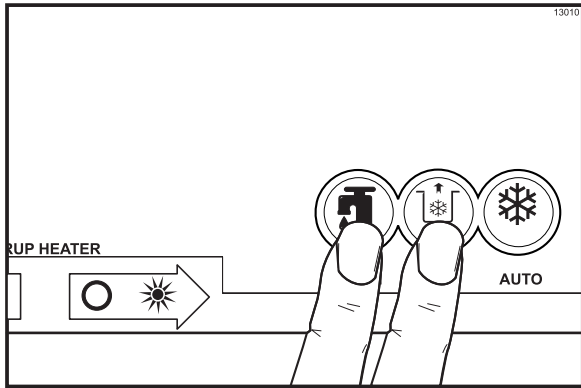

Figure 59

Note: Be sure your hands are clean and sanitized before going on in these instructions.

Step 11

Press the CAL keypad and place the agitator on the agitator drive shaft housing. (See Figure 60.)

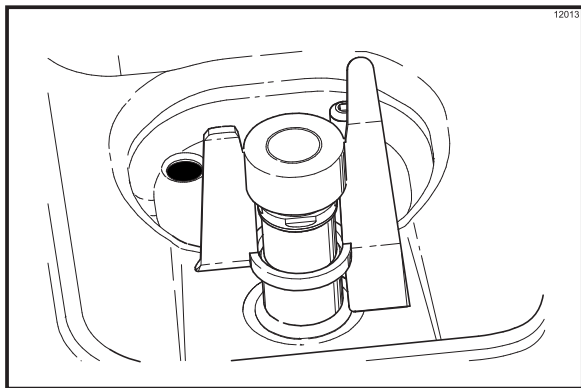

Figure 60

Note: If agitator should stop turning during normal operation, with **sanitized hands**, remove agitator from agitator drive shaft housing and brush clean with sanitizing solution. Install the agitator back onto the agitator drive shaft housing.

Step 12

Stand the mix feed tube in the corner of the mix hopper. Place the cotter pin in position in the outlet fitting of the pump. (See Figure 61.)

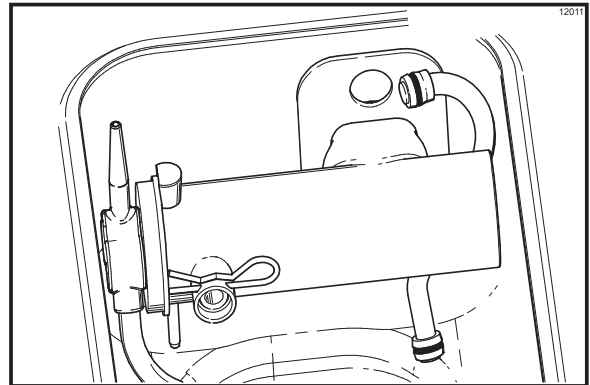

Figure 61

Step 13

Remove the design cap.

Step 14

Return to the freezer with a small amount of sanitizing solution. Dip the door spout brush into the sanitizing solution and brush clean the door spout and bottom of the draw valve.

Note: To assure sanitary conditions are maintained, brush clean each item for a total of 60 seconds, repeatedly dipping the brush in sanitizing solution.

Install the design cap.

Note: You have just sanitized all food contact surfaces of the freezer.

Priming - Shake Side

Note: Evaluate the condition of LED's (lights) and screen messages before performing priming procedures. If all 4 LED's are flashing, the unit is locked.

Step 1

With a mix pail beneath the door spout, open the draw valve. Pour 2-1/2 gallons (9.5 liters) of FRESH mix into the mix hopper and allow it to flow into the freezing cylinder. This will force out any remaining sanitizing solution. When full strength mix is flowing from the door spout, close the draw valve.

Step 2

When mix stops bubbling down into the freezing cylinder, insert the mix feed tube. Remove the cotter pin from the outlet fitting of the mix pump. Insert the outlet end of the mix feed tube into the mix inlet hole in the mix hopper. Place the inlet end of the mix feed tube into the outlet fitting of the mix pump. Secure with cotter pin. (See Figure 62.)

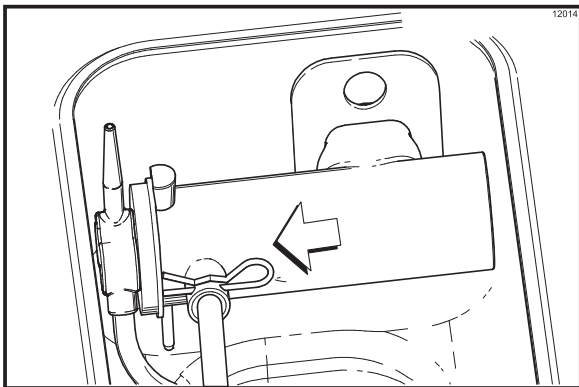

Figure 62

Step 3

Install the shake cup holder. (See Figure 63.)

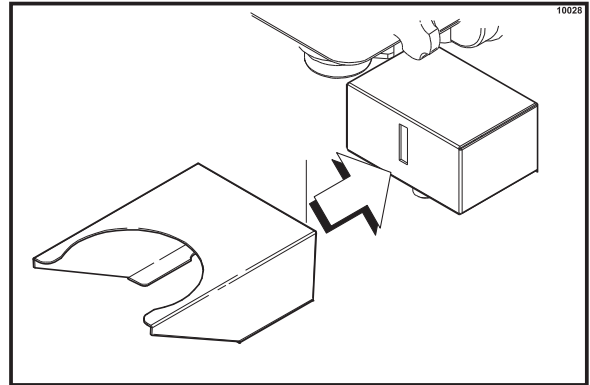

Figure 63

Step 4

Press the AUTO keypad. (See Figure 64.)



Figure 64

Note: This procedure should be done 3-4 hours before the first shake is served, to build up ice crystals.

Step 5

Fill the hopper with fresh mix and place the mix hopper cover in position.

Note: Use only **FRESH** mix when priming the freezer.

Priming - Soft Serve Side

Step 1

With a mix pail beneath the door spout, open the draw valve. Pour 2-1/2 gallons (9.5 liters) of FRESH mix into the mix hopper and allow it to flow into the freezing cylinder. This will force out any remaining sanitizing solution. When full strength mix is flowing from the door spout, close the draw valve.

Step 2

When mix stops bubbling down into the freezing cylinder, insert the mix feed tube. Remove the cotter pin from the outlet fitting of the mix pump. Insert the outlet end of the mix feed tube into the mix inlet hole in the mix hopper. Place the inlet end of the mix feed tube into the outlet fitting of the mix pump. Secure with cotter pin.

Step 3

Press the AUTO keypad.

Note: This procedure should be done 15 minutes before product is expected to be served.

Step 4

Fill the hopper with fresh mix and place the mix hopper cover in position.

Note: Use only **FRESH** mix when priming the freezer.

Daily Closing Procedures

THIS PROCEDURE MUST BE PERFORMED ONCE EVERY 24 HOURS.

The function of the Heat Treatment Cycle is to destroy bacteria by raising the temperature of the mix in the freezing cylinder and the hopper to a specified temperature for a specified period of time, and then bringing the temperature back down low enough to retard spoilage.

The Heat Treatment Cycle will start at the time designated in the Auto Heat Time.



DO NOT draw product or attempt to disassemble the unit during the HEAT cycle. The product is hot and under extreme pressure.

Important: The level of mix in the mix hopper must be above the mix low probe. (The mix low light must **not** be on.)

Shake Side

Note: If the CLEAN MANUALLY light is flashing, do not add mix. The machine must be disassembled and brush cleaned within 24 hours.

Both sides of the freezer must be in the AUTO mode before the HEAT cycle may be started.

AUTO	:MODE:	AUTO
OK	:MIX:	OK
40.0F	HOPPER	40.0F
BRUSH CLEAN ON:	MM/DD	

Figure 65

Step 1

Remove the hopper cover. Remove the shake cup holder, front drip tray, splash shield, and all five drip pans (two from the rear panel, one from the front panel, and two from the side panels).

Make sure your hands are clean and sanitized before performing these next steps.

Note: Pressing the CAL keypad will stop agitator movement for 10 seconds. After 10 seconds have elapsed, press the CAL keypad again to return to the normal display.

Step 2

Remove the agitator from the mix hopper. Remove the restrictor cap from the freezer door spout. Take the agitator, hopper cover, shake cup holder, drip pans, front drip tray, splash shield and restrictor cap to the sink for further cleaning and sanitizing.

Take the syrup hole plugs, spout cap, and spout cap o-ring to the sink for further cleaning and sanitizing.

Rinse these parts in cool, clean water. Prepare a small amount of an approved cleaning solution (example: Kay-5® or Stera-Sheen®). USE WARM WATER AND FOLLOW THE MANUFACTURER'S SPECIFICATIONS to brush clean the parts. Place the restrictor cap, front drip tray, shake cup holder and splash shield on a clean, dry surface to air-dry overnight or until the heating cycle is complete.

Prepare a small amount of an approved 100 PPM sanitizing solution. USE WARM WATER AND FOLLOW THE MANUFACTURER'S SPECIFICATIONS, and sanitize the syrup hole plugs, spout cap, spout cap o-ring, rear drip pan, agitator, and hopper cover.

Step 3

Important: Install the agitator back onto the agitator drive shaft housing. Replace the hopper cover. (See Figure 66.)

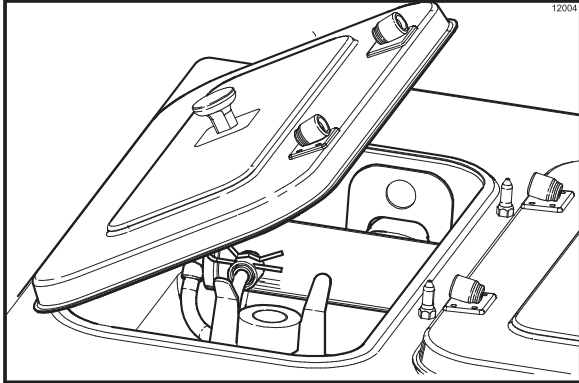

Figure 66

Step 4

Remove the syrup lines from the freezer door.

Step 5

Return to the freezer with a small amount of cleaning solution. With a pail below the door spout, dip the door spout brush into the cleaning solution and brush clean the syrup ports in the freezer door, door spout and bottom of the driven spinner, spinner blade, and syrup line fittings. (See Figure 67.)

Note: To assure sanitary conditions are maintained, brush each item for a total of 60 seconds, repeatedly dipping the brush in cleaning solution.

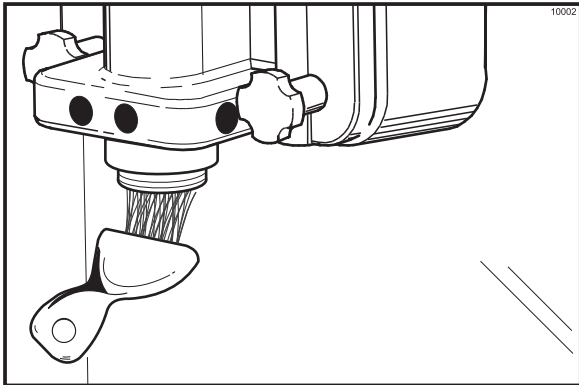

Figure 67

With the syrup port brush, brush each syrup port hole 10 to 15 times. Dip the brush in the cleaning solution before brushing each port. (See Figure 68.)

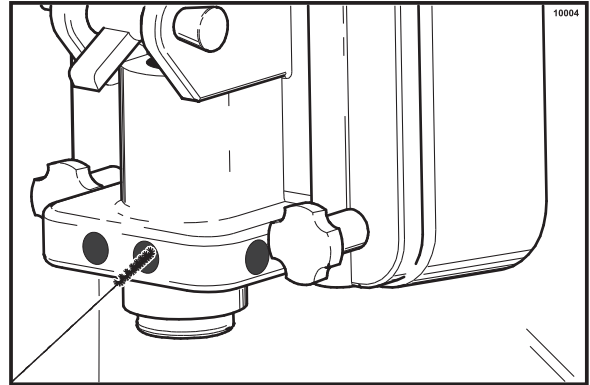

Figure 68

Fill the squeeze bottle with cleaning solution. With a pail beneath the door, insert the adapter end of the squeeze bottle into the syrup port, and squeeze the bottle firmly. This action will force solution out of the adjacent port and down around the spinner. This procedure should be performed for at least 10 seconds per port. (See Figure 69.)

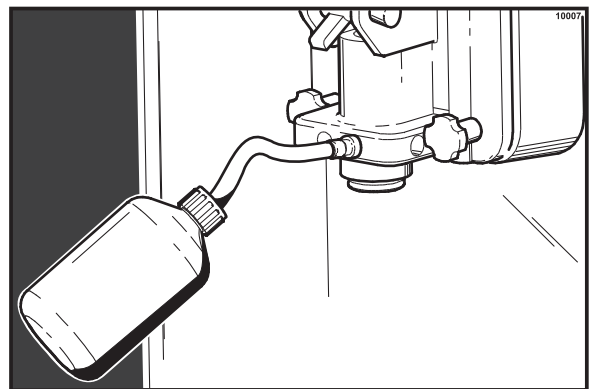

Figure 69

Place the spout cap o-ring in the spout cap. Fill the spout cap with sanitizing solution. While holding the draw valve closed, install the spout cap over the end of the door spout. This will cause sanitizing solution to back flow through the syrup ports. (See Figure 70.)

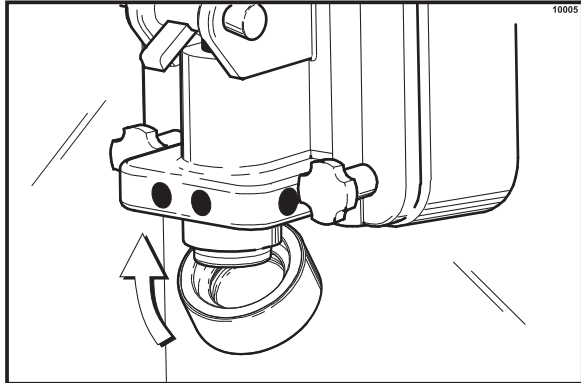

Figure 70

Install the syrup hole plugs in the syrup ports in the freezer door. (See Figure 71.)

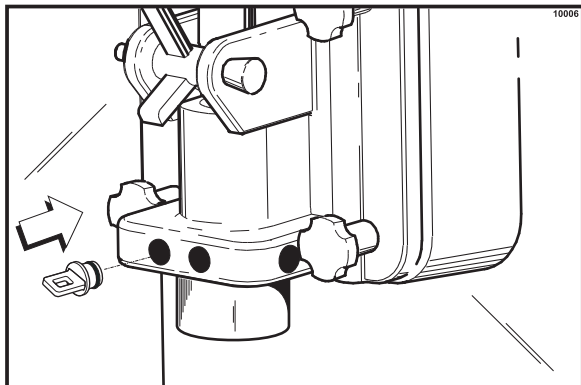

Figure 71

Rinse a single service towel in cleaning solution and wipe down the freezer door and area around the bottom of the freezer door.

Soft Serve Side

THIS PROCEDURE MUST BE DONE ONCE EVERY 24 HOURS.



DO NOT draw product or attempt to disassemble the unit during the HEAT cycle. The product is hot and under extreme pressure.

Important: The level of mix in the mix hopper must be above the mix low probe.

Note: If the CLEAN MANUALLY light is flashing, do not add mix. The machine must be disassembled and brush cleaned within 24 hours.

Both sides of the freezer must be in the AUTO mode before the HEAT cycle may be started.

Step 1

Place the heater switches in the OFF position. (See Figure 72.)

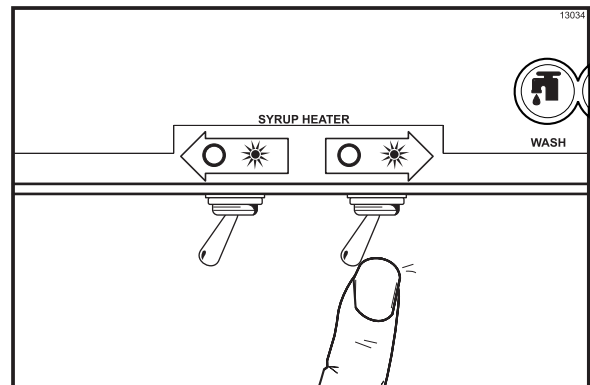

Figure 72

Step 2

Remove the hopper cover.

MAKE SURE YOUR HANDS ARE CLEAN AND SANITIZED BEFORE PERFORMING THESE NEXT STEPS.

Note: Pressing the CAL key will stop agitator movement for 10 seconds. At end of 10 seconds, press the CAL key again to return to the mode screen.

Remove the agitator from the mix hopper. Remove the design cap from the freezer door spout. Take the agitator, hopper cover and design cap to the sink for further cleaning and sanitizing.

Rinse these parts in cool, clean water. Prepare a small amount of an approved cleaning solution (example: Kay-5® or Stera-Sheen®). USE WARM WATER AND FOLLOW THE MANUFACTURER'S SPECIFICATIONS and brush clean the parts. Place the design cap on a clean, dry surface to air-dry overnight or until the heating cycle is complete.

Prepare a small amount of an approved 100 PPM sanitizing solution in WARM WATER AND FOLLOW THE MANUFACTURER'S SPECIFICATIONS and sanitize the agitator and hopper cover.

Step 3

Important: Install the agitator back onto the agitator drive shaft housing. Replace the hopper cover.

Step 4

Return to the freezer with a small amount of cleaning solution. Dip the door spout brush into the cleaning solution and brush clean the door spout and bottom of the draw valve. (See Figure 73.)

Note: To assure sanitary conditions are maintained, brush each item for a total of 60 seconds, repeatedly dipping the brush in cleaning solution.

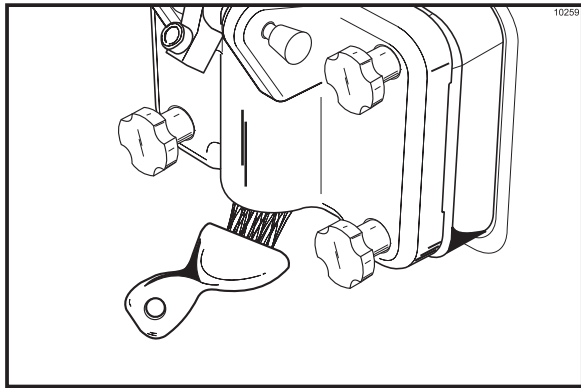

Figure 73

Remove, clean and reinstall the long drip pan through the front panel and the two short drip pans in the rear panel. (See Figure 74.)

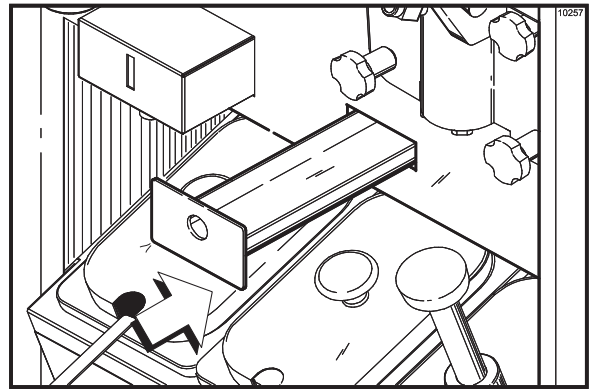

Figure 74

Remove, clean and reinstall the two notched drip pans in the left and right side panels. (See Figure 75.)

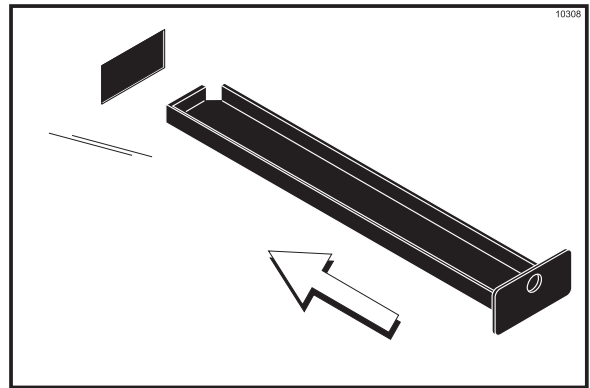

Figure 75

Rinse a single service towel in cleaning solution and wipe down the freezer door and the area around the bottom of the freezer door.

Note: Once the heating cycle has started, it cannot be interrupted. The heating cycle will take a maximum of 4 hours to complete with full hoppers.



CAUTION: Do not draw product during the heating cycle because of high product temperatures.

When the heating cycle is complete, the control will return to the STANDBY mode.

There are 3 phases of the heat cycle: Heating, Holding and Cooling. Each phase has a time limit. If any one of the three phases fail to reach the proper temperatures within the time limit, the cycle will automatically abort and return to the STANDBY mode. The LCD will display the message: HEAT TREAT CYCLE FAILURE - FREEZER LOCKED - PRESS SEL KEY. The product may not be safe to serve. The freezer will be locked out of the AUTO mode. Discard the product and brush clean the machine.

Daily Opening Procedures

Evaluate the condition of LED's (lights) and screen messages (Hard Lock or Soft Lock, etc.) before performing opening procedures. As indicated in the illustration below, 4 flashing LED's, indicate a "locked" condition.

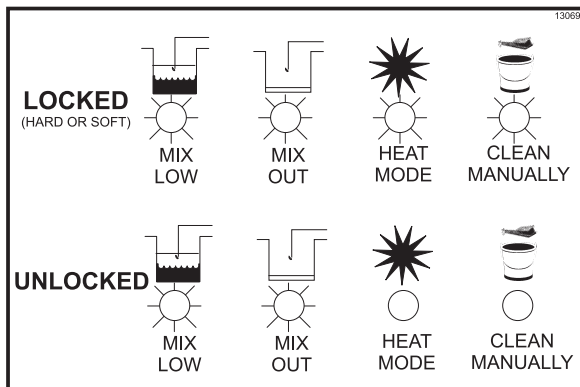

Figure 76



MAKE SURE YOUR HANDS ARE CLEAN AND SANITIZED BEFORE PERFORMING THESE NEXT STEPS.

Step 1

With the drain plugs closed, check the water level in the two heated topping wells. Fill the wells with water to the indicating mark on the bottom of the well.

Step 2

Place the heater switches in the ON position.

Caution: As soon as the heater switches are turned on, the topping wells will begin heating. This heating process will take 2-1/2 hours to reach temperature. The water level in the wells should be checked daily.

Step 3

Prepare a pail of an approved 100 PPM sanitizing solution (examples: 2-1/2 gal. [9.5 liters] of Kay-5® or 2 gal. [7.6 liters] of Stera-Sheen®). USE WARM WATER AND FOLLOW THE MANUFACTURER'S SPECIFICATIONS. Sanitize the topping pumps by placing the entire pump assembly in the pail of sanitizing solution. Pump the solution through to thoroughly sanitize the pump.

Step 4

Fill all four topping containers with topping. Place the stainless steel topping containers in the heated wells. Place the remaining two topping containers in the unheated wells. Cover the containers.

Step 5

Sanitize the two topping ladles and place in the cold topping containers. Place the topping pumps in the heated topping containers.

Shake Side

Step 1

When the heating cycle is complete, the normal display will appear, showing the machine in the STANDBY mode. Prepare a small amount of an approved 100 PPM sanitizing solution (example: Kay-5® or Stera-Sheen®) in WARM WATER AND FOLLOW THE MANUFACTURER'S SPECIFICATIONS.

Step 2

Remove the syrup hole plugs and spout cap with o-ring from the freezer door. Sanitize the restrictor cap, syrup hole plugs, spout cap and o-ring, shake cup holder, front drip tray and splash shield, in this solution.

Step 3

Return to the freezer with a small amount of sanitizing solution. With a pail below the door spout, dip the door spout brush into the sanitizing solution and brush clean the syrup ports in the freezer door, door spout, bottom of the driven spinner and spinner blade, and syrup line fittings. (See Figure 77.)

Note: To assure sanitary conditions are maintained, brush clean each item for a total of 60 seconds, repeatedly dipping the brush in sanitizing solution.

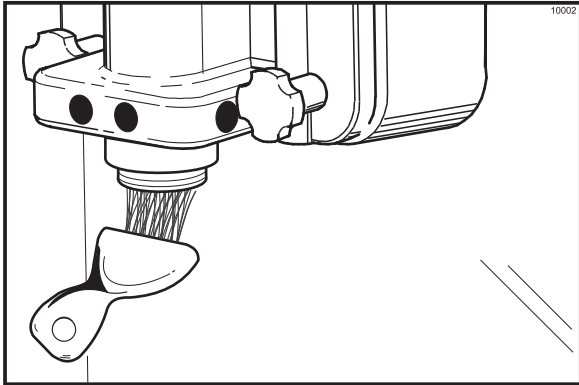

Figure 77

With the syrup port brush, brush each syrup port hole 10 to 15 times. Dip the brush in sanitizing solution before brushing each port. (See Figure 78.)

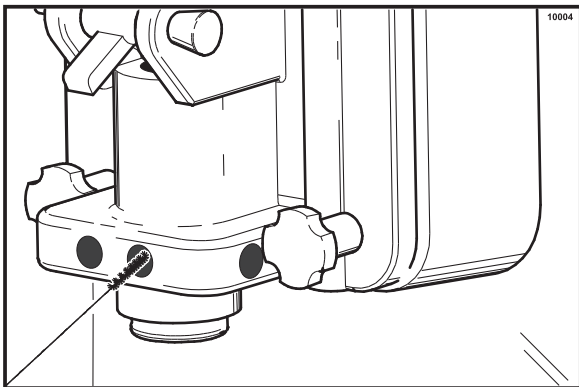

Figure 78

Fill the squeeze bottle with sanitizing solution. With a pail beneath the door, insert the adapter end of the bottle into the syrup port, and squeeze the bottle firmly. This action will force solution out of the adjacent port and down around the spinner. This procedure should be performed for at least 10 seconds per port. (See Figure 79.)

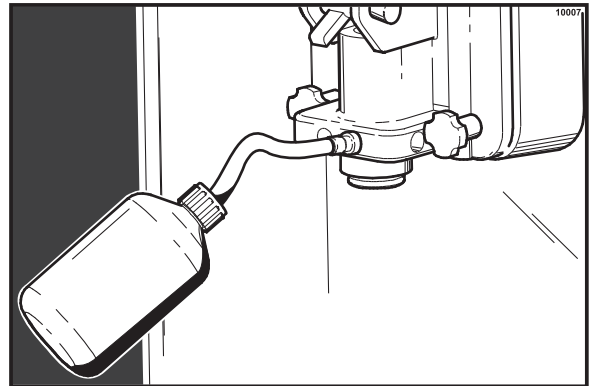

Figure 79

Install the restrictor cap on the freezer door spout. (See Figure 80.) Rinse a single service towel (clean, sanitized towel directly removed from the sanitizer bucket) in sanitizing solution, and wipe down the freezer door and area around the bottom of the freezer door. Install the shake cup holder.

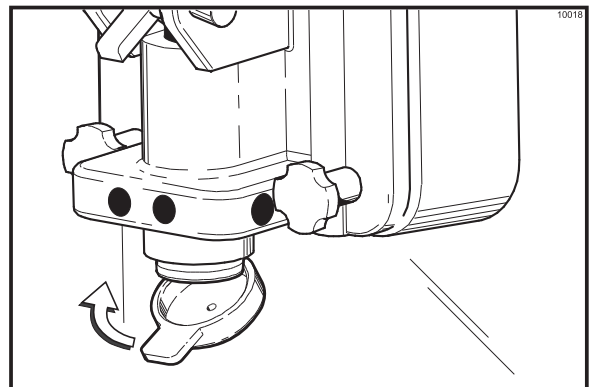

Figure 80

Step 4

When ready to resume normal operation, press the AUTO keypad. (See Figure 81.)

Note: This procedure should be done 3–4 hours before the first shake is served, to build up ice crystals.

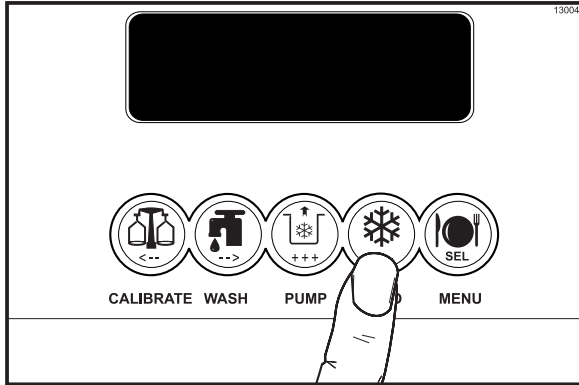

Figure 81

Soft Serve Side

Step 1

Prepare a small amount of an approved 100 PPM sanitizing solution (example: Kay-5® or Stera-Sheen®). USE WARM WATER AND FOLLOW THE MANUFACTURER'S SPECIFICATIONS. Sanitize the design cap in this solution.

Step 2

Return to the freezer with a small amount of sanitizing solution. Dip the door spout brush into the sanitizing solution and brush clean the door spout, and bottom of the draw valve. (See Figure 82.)

Note: To assure sanitary conditions are maintained, brush clean each item for a total of 60 seconds, repeatedly dipping the brush in sanitizing solution.

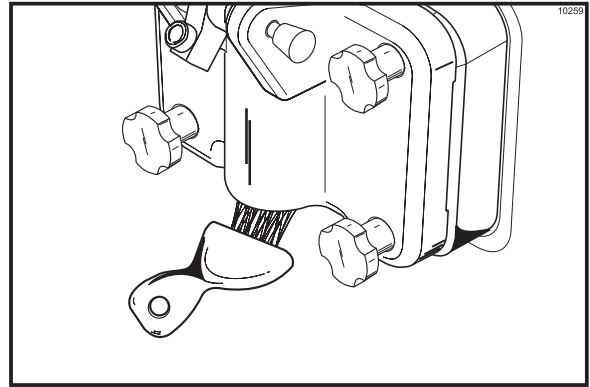

Figure 82

Install the design cap on the freezer door spout. (See Figure 83.) Rinse a single service towel in sanitizing solution, and wipe down the freezer door and area around the bottom of the freezer door. Replace the front drip tray and splash shield.

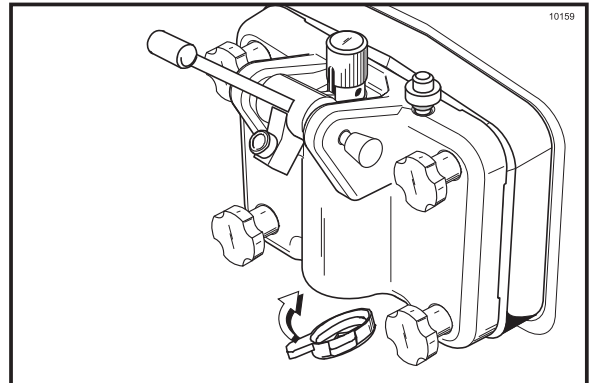

Figure 83

Step 3

When ready to resume normal operation, press the AUTO keypad. (See Figure 84.)

Note: This procedure should be done 15 minutes before product is expected to be served.

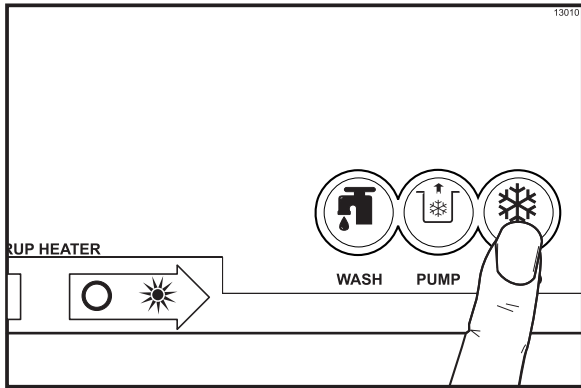

Figure 84

Syrup System

Two main objectives in your opening procedures must be to: (1) fill the syrup tanks, and (2) calibrate the syrup flow. This must be checked **daily** to insure the high quality shake you desire.

Discard syrup weekly and flush syrup lines at least once a week. This will prevent syrup clogging the lines and will break the bacteria chain. See page 60 to sanitize the syrup system.

The syrup tanks are located in the lower front syrup compartment. The syrup lines are color spiral wrapped. Be sure to match the color wrapped syrup line to the correct syrup flavor. (See Figure 85.)

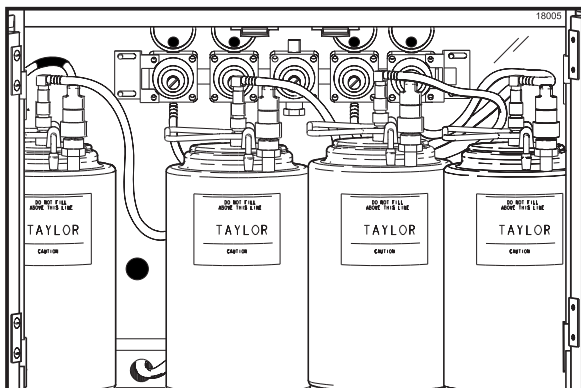

Figure 85

Note: Vanilla and strawberry syrup lines use restrictors at the syrup tank quick disconnect connection to maintain proper calibration. If thin viscosity syrups are used in the special tank, it will be necessary to install a restrictor in the syrup line connection.

Unscrew the quick disconnect from the elbow portion of the syrup line. Make sure the o-ring rests on the end of the quick disconnect fitting. Place the restrictor on top of the o-ring and screw the quick disconnect back onto the syrup line.

Step 1

Filling the syrup tanks: Pull back on the collar of the quick disconnect fitting for the air line. Allow the air pressure to escape from the syrup tank. (See Figure 86.)

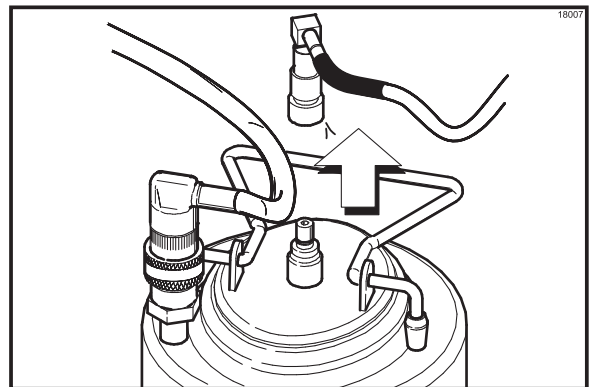

Figure 86

Disconnect the syrup line after you have disconnected the air line. (See Figure 87.)

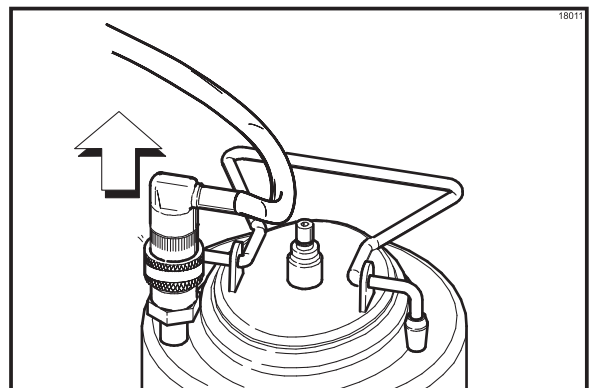

Figure 87

Remove the syrup tank from the compartment. Remove the syrup tank lid by lifting up on the locking lever. Fill the syrup tank with syrup to the indicating mark on the label. DO NOT overfill the tanks. (See Figure 88.)

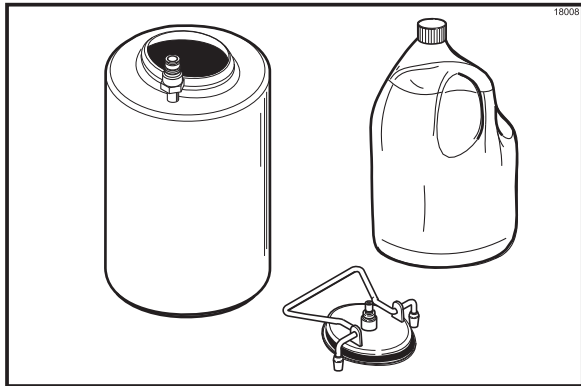

Figure 88

Replace the tank lid, match and connect the spiral wrapped syrup line to the syrup tank. Connect the air line to the syrup tank.

Repeat this procedure for all syrup tanks.

Step 2

Calibrating the syrup flow must be done on a daily basis. It is vital that the correct amount of syrup be incorporated into the mix to obtain a quality shake. The cause of too thin shakes is often too much syrup. The cause of too thick shakes is often too little syrup.

To determine the rate of syrup flow, you will need a syrup sampler and a calibration cup indicating fluid ounces. The proper rate of syrup flow is 1 fl. oz. (30 ml.) of syrup in 5 seconds. Once this rate is set, the correct amount of syrup will be blended with the shake base regardless of the size of shake served. (See Figure 89.)

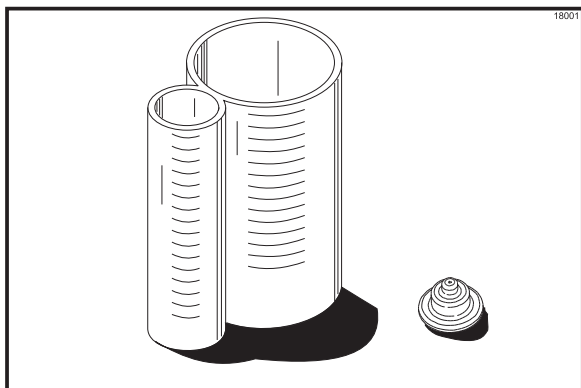

Figure 89

Install the syrup sampler to the fitting on one of the syrup lines. (See Figure 90.)

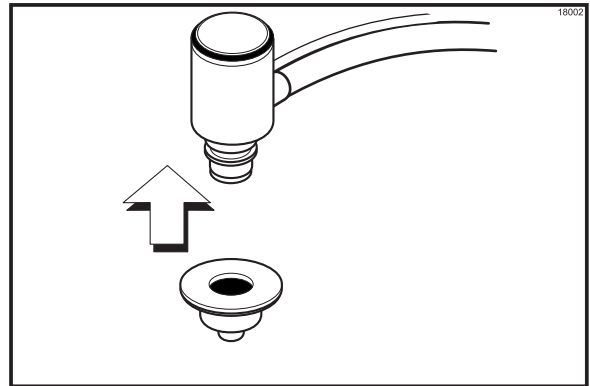

Figure 90

Push the corresponding flavor button for that syrup flavor. (See Figure 91.)

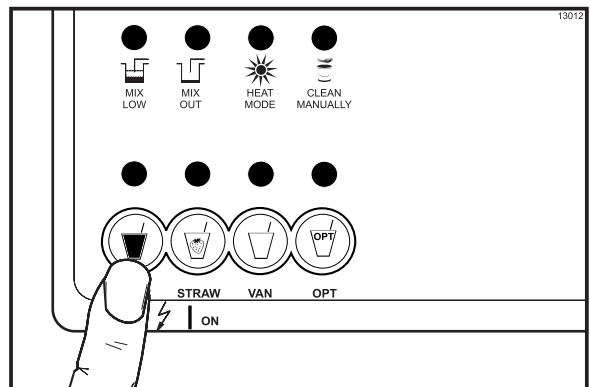

Figure 91

Hold an empty courtesy cup beneath the exit point of the syrup line. Press the CAL keypad (calibrate). A message will appear on the LCD. (See Figure 92.)

SYRUP SYSTEM PRESS		
AUTO	---	START CAL
WASH	---	CONTINUOUS
CAL	---	STOP

Figure 92

Press the WASH keypad. This will bleed any air pockets from the syrup line.

When a STEADY stream of syrup is flowing into the cup, press the CAL keypad to stop the syrup flow. Discard the syrup in the cup. (See Figure 93.)

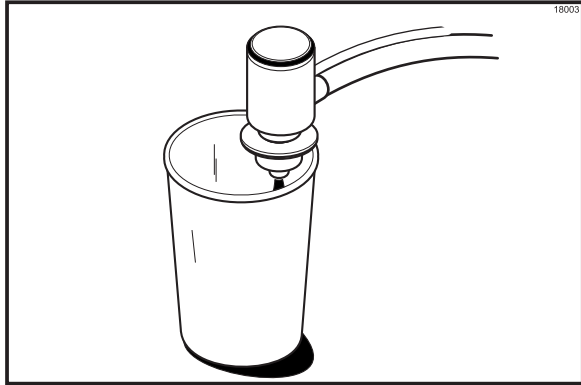

Figure 93

Hold the small portion of the calibrating cup under the syrup line with the syrup sampler. Press the CAL keypad. Press the AUTO keypad to check the rate of syrup flow. After 5 seconds the flow of syrup will automatically stop. If the amount of syrup received is 1 fl. oz. (30 ml.), the syrup is properly calibrated. (See Figure 94.)

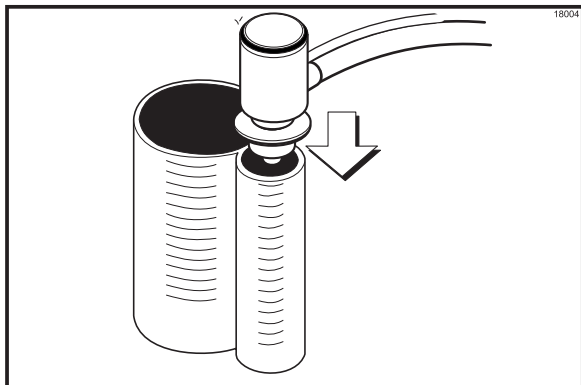

Figure 94

Step 3

Adjusting the syrup pressure: If the amount of syrup is less than 1 fl. oz. (30 ml.) the syrup pressure must be increased. If the amount of syrup is more than 1 fl. oz. (30 ml.) the pressure must be decreased.

Inside the syrup compartment is a regulator manifold assembly with individual pressure regulators to control the amount of pressure to each tank and syrup line. (See Figure 95.)

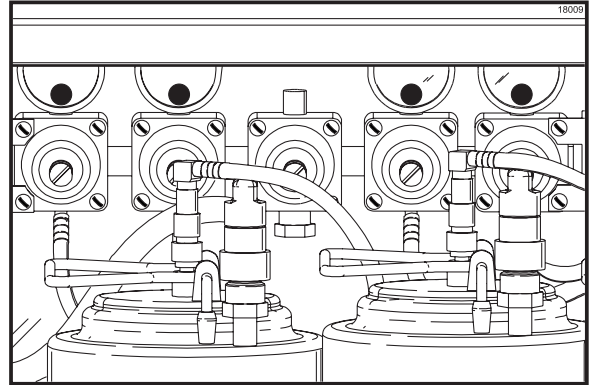

Figure 95

If less than 1 fl. oz. (30 ml.) is received, the pressure must be increased. Loosen the lock nut. Using a flat blade screwdriver, turn the adjusting screw CLOCKWISE.

Recheck the syrup calibration. Tighten the lock nut after the correct calibration is achieved.

If more than 1 fl. oz. (30 ml.) is received, the pressure must be decreased. Loosen the lock nut and turn the adjusting screw COUNTERCLOCKWISE to zero. Remove the air line to the syrup tank to allow the pressure in the tank to escape. Reconnect the air line. Adjust the regulator to the new pressure setting and recheck the syrup calibration. Tighten the lock nut.

Repeat the calibration procedures for each additional syrup line.

Step 4

Remove the syrup sampler. Lightly lubricate the o-ring on each syrup line fitting. (See Figure 96.)

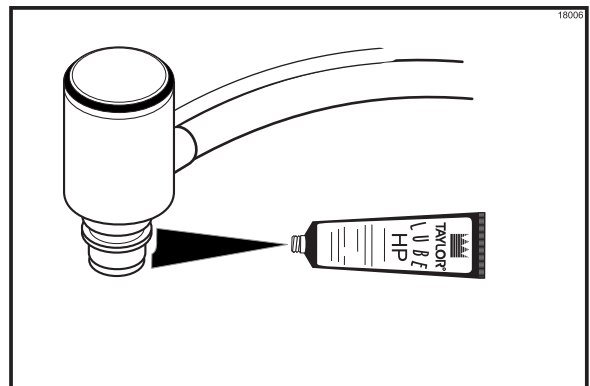

Figure 96

Attach the syrup lines to the freezer door. Insert the syrup line fitting into the syrup port in the freezer door. The flat side of the syrup line fitting must be aligned with the pin in the syrup port. Rotate the syrup line fitting upward to lock in place. (See Figure 97.)

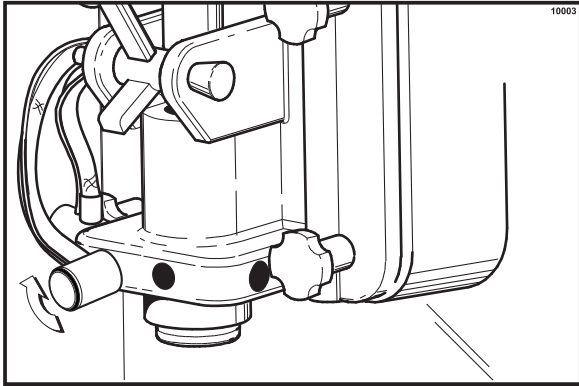

Figure 97

Note: Whenever a particular syrup line is not used, the syrup hole plug found in the spare parts kit must be installed. Place the syrup hole plug o-ring into the groove of the syrup hole plug and lubricate. Align the flat portion of the syrup hole plug with the locking pin in the open syrup port of the freezer door. Insert the syrup hole plug and turn slightly to lock in place.

Step 5

Clean the calibration cup and syrup sampler.

This Procedure Must be Performed Daily!

Syrup Pump

Syrup Pump Disassembly

Before the first use, and after use daily, disassemble and clean the pump.

Step 1

Flush and rinse the pump in a container of warm water. Place the lower end of the pump into the water container. Operate the pump until only warm water flows from the discharge tube.

Step 2

Remove the pump from the container of water for disassembly.

Step 3

Remove the plunger assembly from the pump body by turning the plunger nut counterclockwise. (See Figure 98.)

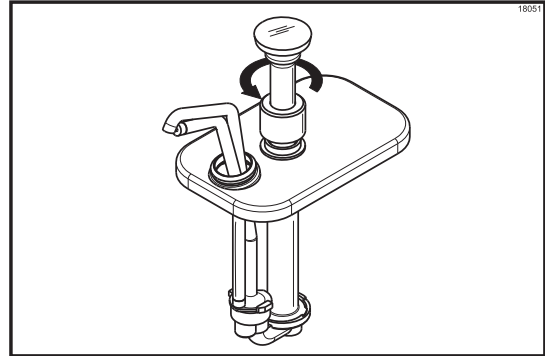

Figure 98

Step 4

To remove the knob, compress the spring toward the knob, using the washer. Compress it enough to grab onto the plunger with your hand for support. Begin removing the knob with your other hand. (See Figure 99.)

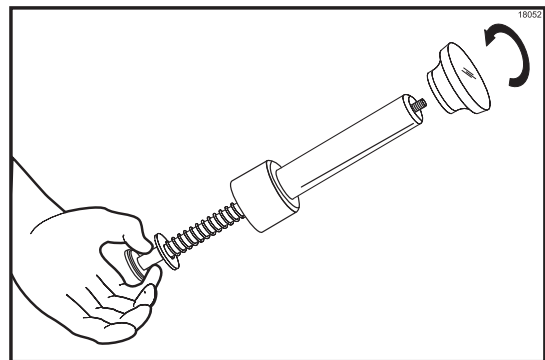

Figure 99

Step 5

Remove the knob o-ring.

Step 6

Remove the plunger nut from the plunger tube.

Step 7

Remove the plunger tube and the insert from the plunger assembly. (See Figure 100.)

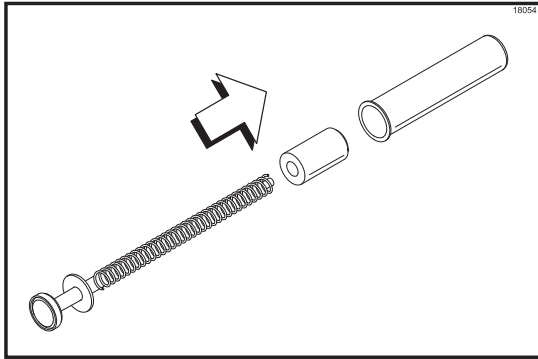

Figure 100

Step 8

Remove the spring and washer from the plunger assembly. (See Figure 101.)

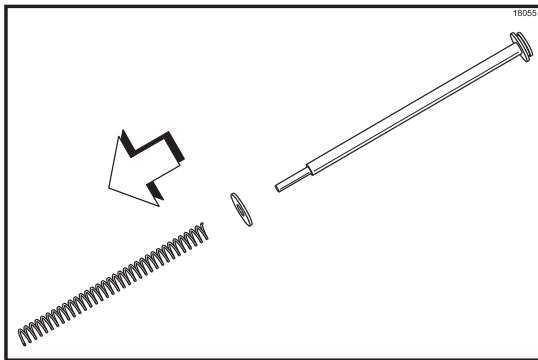

Figure 101

Step 9

Remove the seal assembly from the plunger assembly. (See Figure 102.)

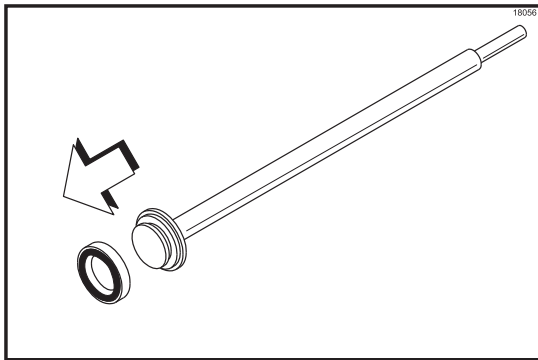

Figure 102

Step 10

Remove the seal o-ring from the seal. (See Figure 103.)

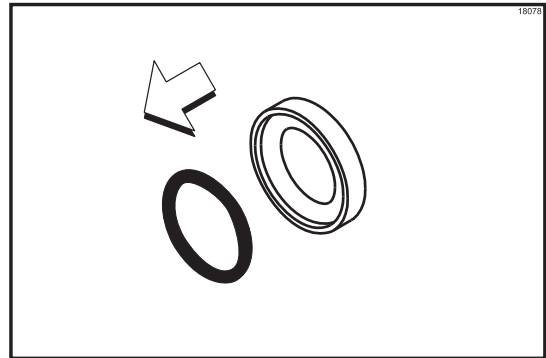

Figure 103

Step 11

Remove the discharge tube lock nut by turning it counterclockwise. Remove the discharge lock nut from the discharge tube. (See Figure 104.)

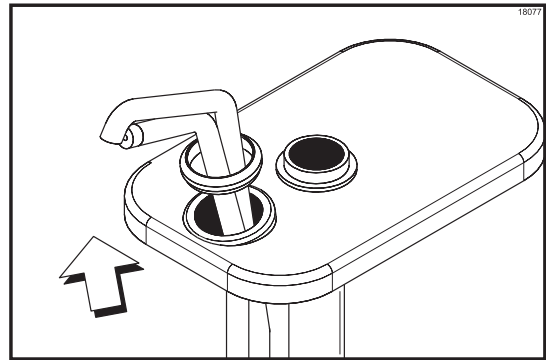

Figure 104

Step 12

Remove the lid by sliding it off the discharge tube.

Step 13

Remove the cylinder from the valve body. (See Figure 105.)

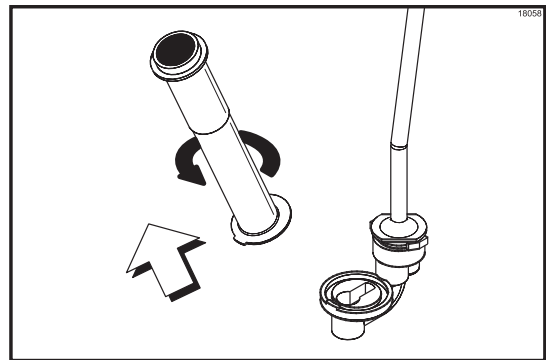

Figure 105

Step 14

Remove the discharge tube from the valve body. (See Figure 106.)

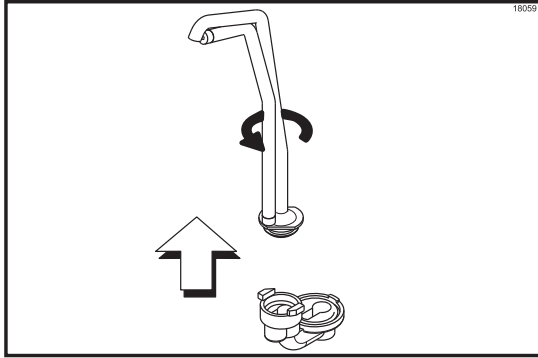

Figure 106

Step 15

Remove the 1-5/16" o-ring from the valve body, and remove the 1" o-ring from the discharge tube.

Cleaning the Syrup Pump

Step 1

Flush and rinse the pump in a container of warm water. Place the lower end of the pump into the water container and operate the pump until only warm water flows from the discharge tube.

Step 2

Remove the pump from the container of water for disassembly.

Step 3

Wash and scrub all parts in clean, warm soapy water. Use the supplied brushes to clean all confined areas.

Step 4

Insert the brush through the tip of the discharge tube. Move the brush back and forth to scrub the tip of the discharge tube. (See Figure 107.)

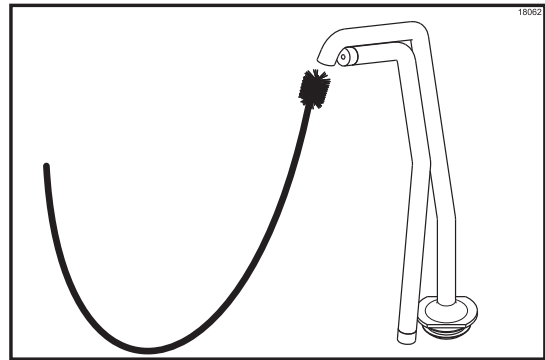

Figure 107

Step 5

Advance the brush completely through the discharge tube and pull the brush from the bottom of the tube.

Step 6

Insert the brush into the top side of the inlet valve. Scrub this area, specifically around the steel ball. (See Figure 108.)

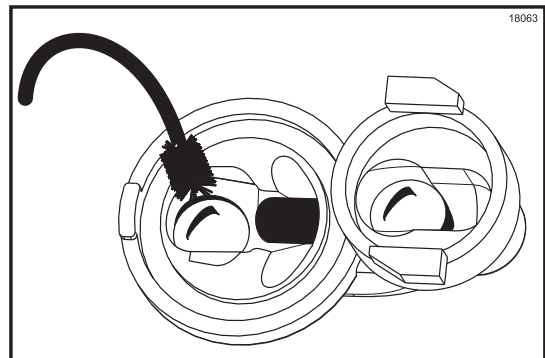

Figure 108

Step 7

Insert the brush into the top side of the outlet valve. Scrub this area, specifically around the steel ball. (See Figure 109.)

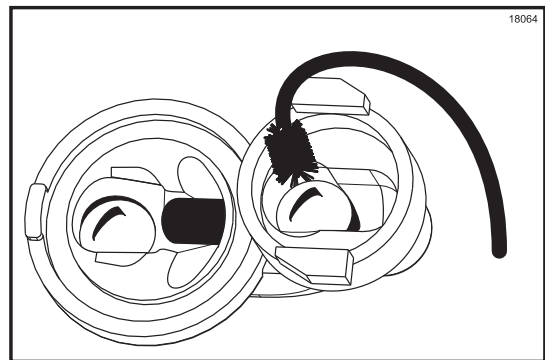

Figure 109

Step 8

Insert the brush, by the non-bristle end, into the passageway between the inlet valve and the outlet valve. (See Figure 110.)

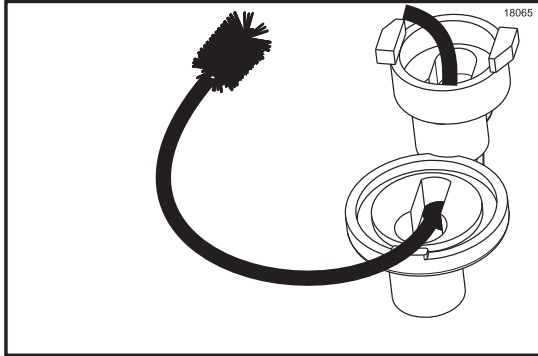

Figure 110

Step 9

Move the brush back and forth to scrub this passageway. Advance the brush completely, and pull the brush out of the valve body. (See Figure 111.)

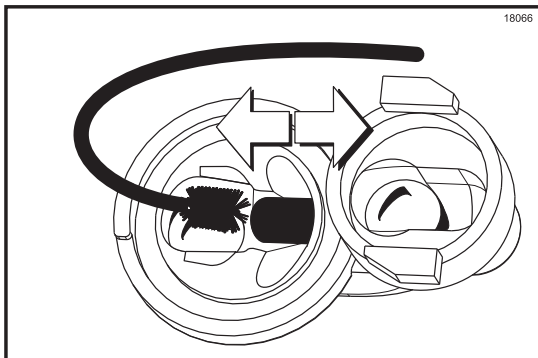

Figure 111

Step 10

Insert the brush into the bottom side of the inlet valve. Move the brush back and forth to scrub this area, specifically around the steel ball. (See Figure 112.)

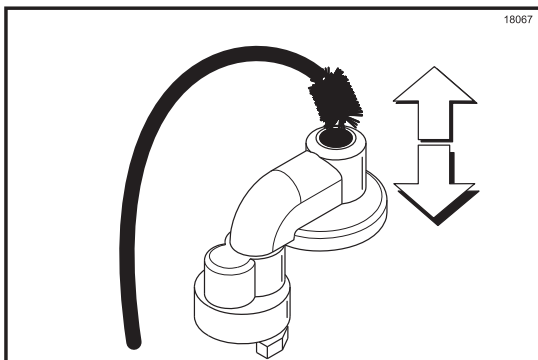

Figure 112

Step 11

Advance the brush completely through the inlet valve, and pull the brush out of the valve body.

Step 12

Rinse all parts with clear water.

Step 13

Sanitize parts following your local sanitization requirements. Allow parts to air dry after sanitization.

Syrup Pump Assembly

After pump disassembly and cleaning, assemble the pump.

Step 1

Lubricate and install the seal o-ring into the seal. (See Figure 113.)

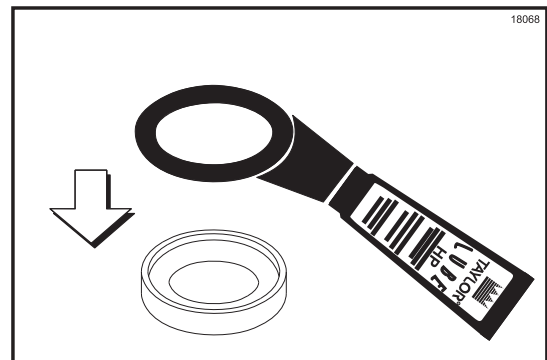

Figure 113

Step 2

Install the seal assembly onto the piston end of the plunger assembly.

Step 3

Install the washer and spring onto the plunger assembly. (See Figure 114.)

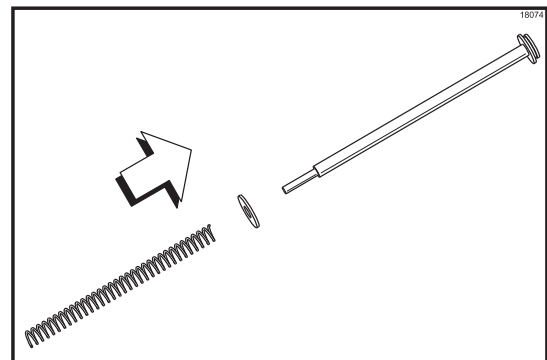

Figure 114

Step 4

Install the plunger insert into the plunger tube by positioning the end of the insert with the beveled edge and smaller hole to enter into the plunger tube first.

Step 5

Install the plunger nut onto the plunger tube.

Step 6

Install the knob o-ring into the groove provided in the knob.

Step 7

Install the plunger tube assembly onto the plunger assembly by inserting the plunger assembly into the larger opening on the plunger tube. Push the plunger assembly, compressing the spring, until the threaded end of the stem projects through the smaller opening on the plunger tube and the insert. (See Figure 115.)

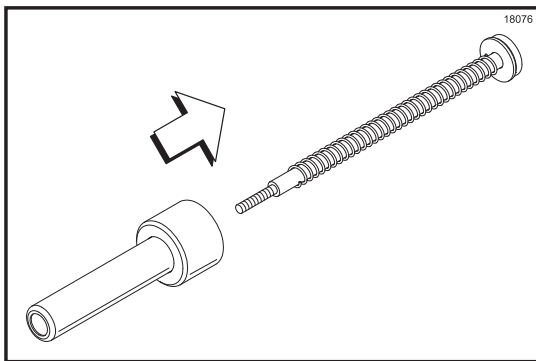

Figure 115

Step 8

Install the knob with the knob o-ring onto the threaded end of the plunger assembly. Hold the plunger assembly so that the plunger tube, compressing the spring, is pulled toward the piston end as far as it will go. Tighten the knob by turning it clockwise.

Step 9

Lubricate and install the 1" o-ring onto the groove provided on the discharge tube. (See Figure 116.)

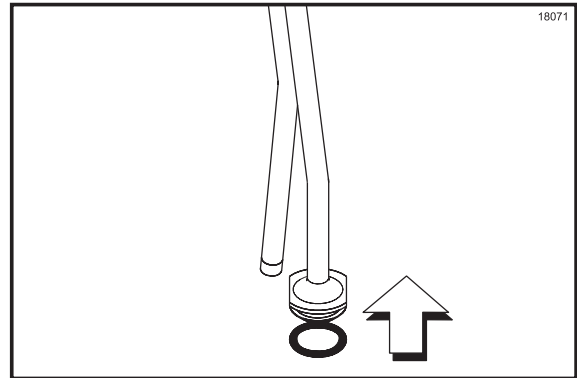

Figure 116

Step 10

Lubricate and install the 1-5/16" o-ring into the valve body. (See Figure 117.)

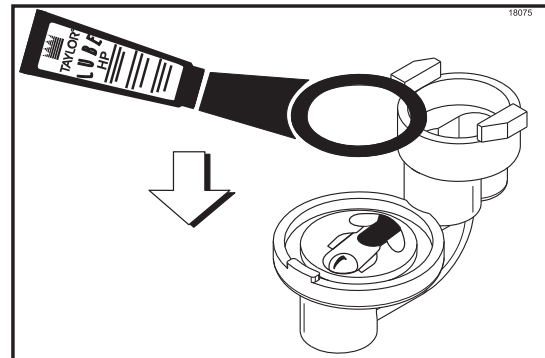

Figure 117

Step 11

Install the discharge tube onto the smaller opening in the valve body by aligning the flats on the discharge tube with the locking grooves on the valve body. Push down the discharge tube until it is seated into the valve body opening. Turn the discharge tube clockwise to fully engage it into locking grooves on the valve body.

Step 12

Install the cylinder onto the larger opening in the valve body by tilting the cylinder away from the discharge tube and sliding the widest section of flange under the center locking groove on the valve body. Align the tabs on the cylinder with the locking grooves on the valve body. Turn the cylinder clockwise until the tabs fully engage into the locking grooves on the valve body.

Step 13

Install the lid by inserting the discharge tube through the smaller hole in the lid. Slide the lid until the larger hole fits around the top of the cylinder. The discharge tube lock nut will secure the lid in position.

Step 14

Install the discharge tube lock nut.

Step 15

Lubricate and install the plunger assembly into the cylinder opening in the pump body. (See Figure 118.)

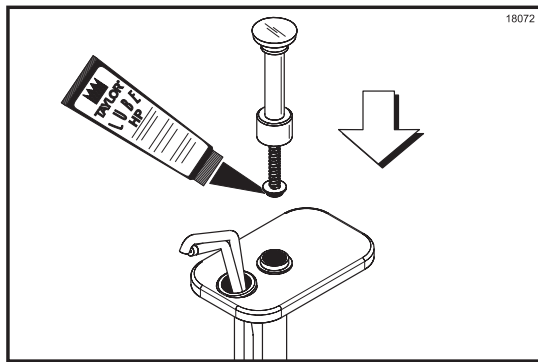

Figure 118

Step 16

Tighten the plunger nut by turning it clockwise. (See Figure 119.)

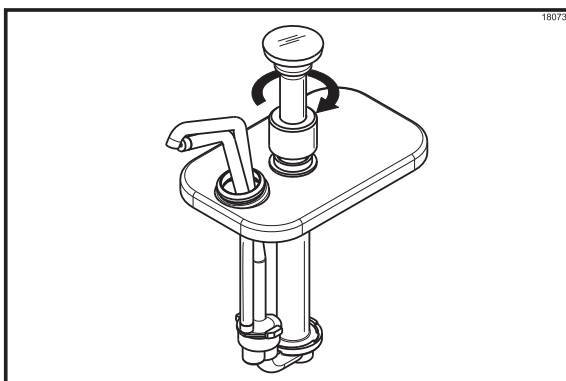

Figure 119

Manual Brush Cleaning

This Procedure Must Be Done Every Two Weeks!



To disassemble the Model PH90, the following items will be needed:

- Two cleaning and sanitizing pails for each side of the freezer
- Necessary brushes (provided with freezer)
- Cleaning solution
- Sanitizing solution
- Single service towels

Draining Product From The Freezing Cylinder

To drain the product from the freezing cylinder for both sides, the steps will be the same. Therefore, first drain the product from the shake side, then go back and duplicate these procedures for the soft serve side.

Step 1

Place the heater switches in the OFF position.

Step 2

Cancel automatic operation by pressing the AUTO keypad. (See Figure 120.)

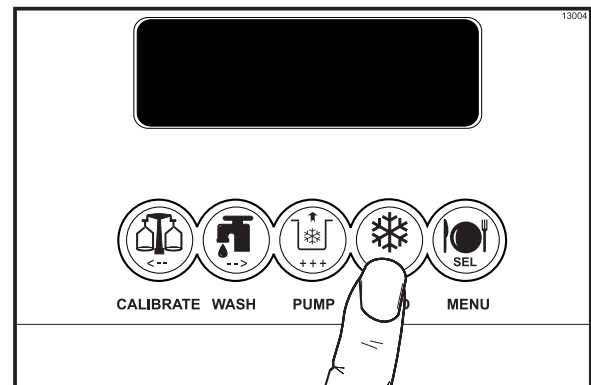

Figure 120

Step 3

Remove the shake cup holder. Set it aside for cleaning later with all parts. **(Shake side only)**

Step 4

Remove the hopper cover and agitator. Take these parts to the sink to wash, rinse and sanitize.

Step 5

With a pail under the door spout, press the WASH and PUMP keypads. Open the draw valve and start to drain the product from the freezing cylinder and mix hopper. (See Figure 121.)

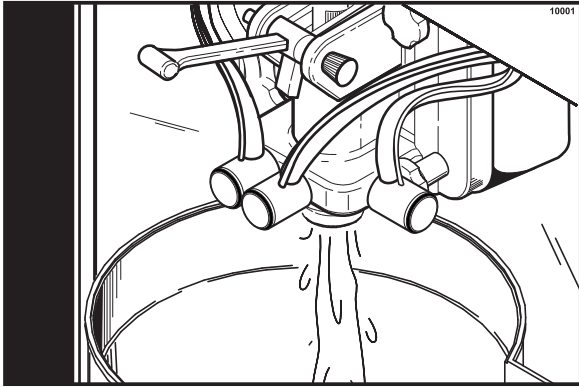

Figure 121

Step 6

When the flow of product stops, press the WASH and PUMP keypads and close the draw valve. **Discard this product.** (See Figure 122.)

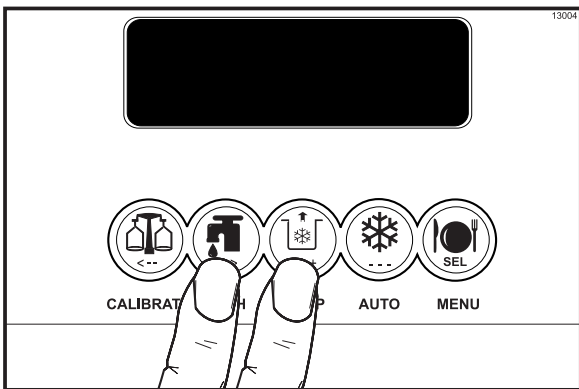

Figure 122

With the parts tray available, remove the following parts and place them in parts tray.

Step 7

Remove the locking clip and mix feed tube. Remove the pump clip and the assembled air/mix pump.

Step 8

Remove the syrup lines from the freezer door by rotating the syrup line fittings and pulling out. **(Shake side only)**

Repeat Steps 2 through 7 for the soft serve side of the freezer.

Rinsing

To rinse both sides of the freezer, the steps will be the same. Therefore, first rinse the shake side, then go back and duplicate these procedures for the soft serve side.

Step 1

Pour two gallons (7.6 liters) of cool, clean water into the mix hopper. With the proper brushes, scrub the mix hopper, mix level sensing probes, the outside of the agitator drive shaft housing, and the mix inlet hole. (See Figure 123.)

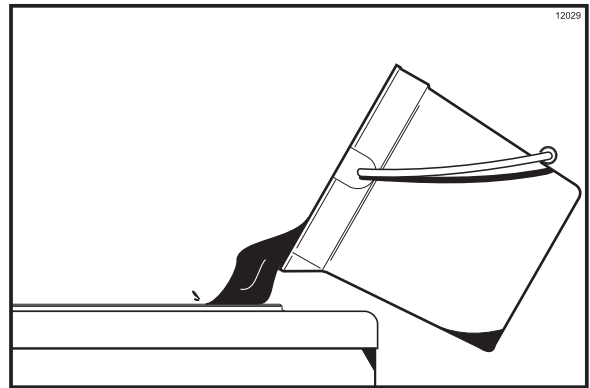

Figure 123

Note: Do not brush clean the mix inlet hole while the machine is in the WASH mode.

Step 2

With a mix pail beneath the door spout, press the WASH keypad. (See Figure 124.)

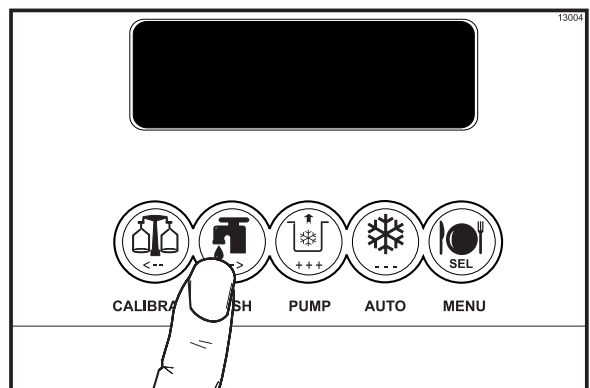

Figure 124

Step 3

Open the draw valve on the freezer door. Drain all the rinse water from the door spout, close the draw valve, and press the WASH keypad, cancelling the wash cycle.

Step 4

Repeat this procedure using clean, warm water, until the water being discharged is clear.

Repeat steps 1 through 4 for the soft serve side of the freezer.

Cleaning and Sanitizing

To clean and sanitize both sides of the freezer, the steps will be the same. Therefore, first clean and sanitize the shake side, then go back and duplicate these procedures for the soft serve side.

Step 1

Prepare a pail of an approved 100 PPM cleaning solution (examples: 2-1/2 gal. [9.5 liters] of Kay-5® or 2 gal. [7.6 liters] of Stera-Sheen®). USE WARM WATER AND FOLLOW THE MANUFACTURER'S SPECIFICATIONS.

Step 2

Pour the cleaning solution into the hopper and allow it to flow into the freezing cylinder.

Step 3

While the solution is flowing into the freezing cylinder, brush clean the mix hopper, mix level sensing probes, the outside of the agitator drive shaft housing, and the mix inlet hole.

Step 4

Press the WASH keypad. This will cause the cleaning solution in the freezing cylinder to be agitated.

Step 5

Place an empty pail beneath the door spout.

Step 6

Open the draw valve on the freezer door and draw off all the solution.

Step 7

Once the cleaner stops flowing from the door spout, close the draw valve and press the WASH keypad, cancelling the wash cycle.

Step 8

Prepare a pail of an approved 100 PPM sanitizing solution (examples: 2-1/2 gal. [9.5 liters] of Kay-5® or 2 gal. [7.6 liters] of Stera-Sheen®). USE WARM WATER AND FOLLOW THE MANUFACTURER'S SPECIFICATIONS.

Repeat steps 2 through 7 with the sanitizing solution.

Repeat steps 1 through 8 for the soft serve side of the freezer.

Disassembly - Shake Side

Note: Failure to remove parts, brush clean and re-lubricate these parts, will result in damage to the related parts. These parts must be removed every 14 days or the machine will lock out and not operate in the AUTO mode.



MAKE SURE POWER SWITCH IS IN THE "OFF" POSITION. Failure to do so may cause injury from hazardous moving parts, or electrocution. (See Figure 125.)

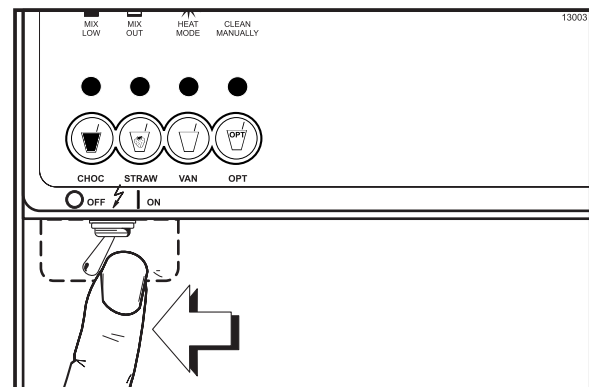

Figure 125

Step 1

Remove the syrup lines from the syrup ports, and remove the restrictor cap from the bottom of the door spout.

Step 2

Remove the spinner blade from the bottom of the door spout by lifting up the plunger nut on the spinner coupling and pulling down the blade.

Step 3

Remove the handscrews, freezer door, beater assembly with drive shaft seal and scraper blades from the freezing cylinder.

Step 4

Remove the drive shaft seal from the drive shaft of the beater assembly.

Step 5

Remove the freezer door o-ring, front bearing, pivot pin, draw handle and draw valve spinner assembly. Remove o-ring from pivot pin.

Disassemble the draw valve spinner assembly. Remove the driven spinner by grasping the draw valve and pulling the driven spinner out. Remove the spinner shaft seal.

Remove the two o-rings from the draw valve.

Step 6

From the shake pump cylinder, remove the retaining pin, valve body, piston, spring and poppet, and the mix inlet tube. Remove all o-rings and check rings.

Step 7

Remove the drive shaft from the drive hub in the rear wall of the mix hopper.

Remove the two small o-rings and one large o-ring from the drive shaft.

Disassembly - Soft Serve Side

Note: Failure to remove parts, brush clean and re-lubricate these parts, will result in damage to the related parts. These parts must be removed every 14 days or the machine will lockout and not operate in the AUTO mode.



MAKE SURE POWER SWITCH IS IN THE "OFF" POSITION. Failure to do so may cause injury from hazardous moving parts, or electrocution.

With the parts tray available for the soft serve side, remove the following parts and place them in the parts tray.

Step 1

Remove the design cap from the bottom of the door spout.

Step 2

Remove the handscrews, freezer door, beater, shoes, scraper blades, and drive shaft from the freezing cylinder.

Step 3

Remove the scraper blade clips from the scraper blades.

Step 4

Remove the pivot pin and draw handle.

Step 5

From the soft serve pump cylinder, remove the retaining pin, valve body, piston, spring and poppet, and the mix inlet tube. Remove all o-rings and check rings.

Step 6

Remove the drive shaft from the drive hub in the rear wall of the mix hopper. (See Figure 126.)

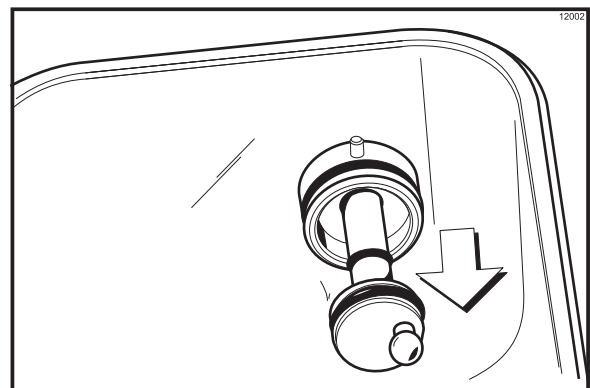

Figure 126

Remove the two small o-rings and one large o-ring from the drive shaft.

Step 7

Remove the front drip tray and splash shield. Remove the ladles from the two cold topping containers.

Step 8

Remove the long drip pan from the front panel, the two short drip pans from the rear panel, and the two notched drip pans from the left and right side panels. Take these items to the sink for cleaning.

Note: If the drip pans are filled with an excessive amount of mix, it is an indication that the drive shaft seals, cup seals or o-rings should be replaced or properly lubricated.

Brush Cleaning

We recommend brush cleaning all the shake parts, then go back and duplicate these steps (where they apply) for brush cleaning all the soft serve parts. By doing so, you will not confuse or interchange these parts for assembly the next morning. Place the parts in their proper place in the parts tray.

Step 1

Prepare a sink with an approved cleaning solution (example: Kay-5® or Stera-Sheen®). USE WARM WATER AND FOLLOW THE MANUFACTURER'S SPECIFICATIONS. If another approved cleaner is used, dilute according to label instructions. (IMPORTANT: Follow label directions, as too STRONG of a solution can cause parts damage, while too MILD of a solution will not provide adequate cleaning.) Make sure all brushes provided with the freezer are available for brush cleaning.

Step 2

Remove the:

- Seal from the drive shaft
- O-rings and guide bearing from the torque rotor
- Draw valve from the freezer door
- O-rings from the draw valve
- Spinner bearing from the draw valve
- Gasket and front bearing from the freezer door.

Note: To remove o-rings, use a single service towel to grasp the o-ring. Apply pressure in an upward direction until the o-ring pops out of its groove. With the other hand, push the top of the o-ring forward, and

it will roll out of the groove and can be easily removed. If there is more than one o-ring to be removed, always remove the rear o-ring first. This will allow the o-ring to slide over the forward rings without falling into the open grooves.

Step 3

Remove the o-rings from the pump feed tubes.

Step 4

Thoroughly brush clean all disassembled parts and parts trays in the cleaning solution, making sure all lubricant and mix film is removed. Be sure to brush all surfaces and holes, especially holes in the pump valve body and the small syrup holes in the shake freezer door.

Rinse all parts with clean, warm water.

Step 5

Return to the freezer with a small amount of cleaning solution and the black brush. Brush clean the rear shell bearings at the back of the freezing cylinders. (See Figure 127.)

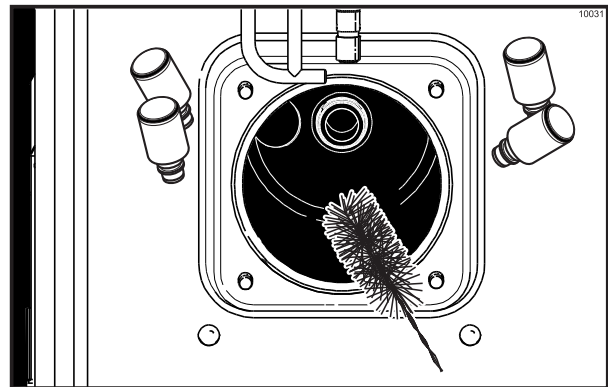

Figure 127

Brush clean the drive hub openings in the rear wall of the mix hoppers. (See Figure 128.)

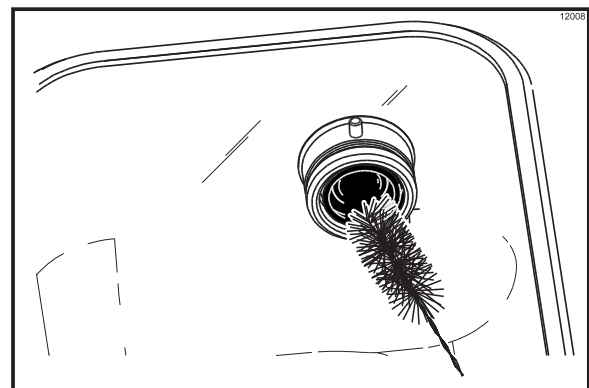

Figure 128

Using small double end brush, brush clean the syrup line fittings.

Step 6

Prepare a sink with an approved 100 PPM sanitizing solution (example: Kay-5® or Stera-Sheen®). USE WARM WATER AND FOLLOW THE MANUFACTURER'S SPECIFICATIONS. Repeat Step 5 with the sanitizing solution.

Step 7

Rinse all parts in the sanitizing solution for a minimum of one minute.

Step 8

Place disassembled parts on clean and sanitized parts trays.

Step 9

Wipe clean all exterior surfaces of the freezer.

Sanitizing the Syrup System

Shake Side:

Two main objectives in your closing procedures must be to:

1. Discard all syrup **at least once a week.**
2. Flush the syrup lines **at least twice a week.**

This must be done on a regular basis

- a. to keep a build-up of old syrup from clogging the lines, and
- b. to break the bacteria chain which develops in the tanks and lines.

Remember: Calibrating the syrup flow must be done once every morning, especially after flushing the syrup lines.

Step 1

Sanitizing the syrup tanks. Pull back on the collar of the quick disconnect fitting of the air line. Allow the air pressure to dissipate from the syrup tank. Disconnect the syrup line.

Remove the syrup tank from its compartment. Remove the syrup tank lid by lifting up on the locking lever, and discard the remaining syrup.

Rinse the syrup tank with clean, warm water.

Prepare 1/2 gallon (1.9 liters) of the recommended sanitizing solution with **warm** water in the syrup tank. Brush clean the inside and outside of the tank. Remove the syrup line fitting. Remove the dip tube and o-ring from the syrup tank.

Thoroughly brush clean the dip tube, syrup line fitting, and o-ring using the sanitizing solution. Reassemble the dip tube, o-ring, and syrup line fitting.

Pour off all the sanitizing solution and place the tank in an upside-down position on a clean, dry surface to air dry.

Repeat this procedure for all the syrup tanks.

Step 2

Sanitizing the syrup lines. Prepare one gallon (3.8 liters) of the recommended sanitizing solution with **warm** water in the spare syrup tank. Replace and lock the tank lid in position. Place this tank in the syrup compartment.

Connect one of the air lines and the corresponding syrup line to the syrup tank filled with sanitizing solution.

Place the power switch in the "ON" position. This will activate the air compressor to supply pressure to the syrup system.

Install the syrup sampler to the fitting of the syrup line.

Press the corresponding flavor button for the syrup line being sanitized.

Place an empty pail beneath the exit point of the syrup line. Press the CAL keypad. A message will appear on the LCD.

Press the WASH keypad. Flush the syrup line until the solution runs clear. Press the CAL keypad to stop the flow of sanitizing solution.

Note: This procedure will thoroughly clean the syrup lines and prevent bacteria build-up.

Turn the syrup tank with the sanitizing solution upside-down. Press the CAL keypad. Press the WASH keypad to clear the syrup line of any remaining sanitizer. When the sanitizer has been flushed from the syrup lines, press the CAL keypad to complete this step.

Repeat this procedure for all syrup lines.

Step 3

Place the power switch to the OFF position.

Section 7 Important: Operator Checklist

During Cleaning and Sanitizing



ALWAYS FOLLOW LOCAL HEALTH CODES.

Cleaning and sanitizing schedules are governed by your State or local regulatory agencies and must be followed accordingly. The following check points should be stressed during the cleaning and sanitizing operations. **CLEANING AND SANITIZING MUST BE PERFORMED EVERY 14 DAYS.**

Troubleshooting Bacterial Count

- 1. Thoroughly clean and sanitize machine regularly, including complete disassembly and brush cleaning.
- 2. Use all brushes supplied for thorough cleaning. The brushes are specially designed to reach all mix passageways.
- 3. Use the white bristle brush to clean the mix inlet hole which extends from the mix hopper down to the rear of the freezing cylinder.
- 4. Use the black bristle brush to thoroughly clean the rear shell bearing located at the rear of the freezing cylinder and the drive hub opening in the rear wall of the mix hopper. Be sure to have a generous amount of cleaning solution on the brush.
- 5. Properly prepare the cleaning and sanitizing solutions. Read and follow label directions carefully. Too strong of a solution may damage the parts and too weak of a solution will not do an adequate job of cleaning or sanitizing.
- 6. Empty all syrup from the tanks and discard at least once a week.
- 7. Thoroughly clean and sanitize the syrup lines at least once a week.
- 8. Temperature of mix in mix hopper and walk-in cooler should be below 40°F. (4.4°C.).
- 9. Discard remaining mix from freezer during “Manual Brush Cleaning”.

Regular Maintenance Checks

- 1. Rotate scraper blades to allow both sides of the knife edge to wear evenly. This will contribute to self-sharpening and help maintain fast, efficient freezing.
- 2. Replace blades that are bent, damaged, or worn.
- 3. Before installing beater, be certain that scraper blades are properly attached over the beater pins.
- 4. Dispose of o-rings and seals that are worn, torn or fit too loosely, and replace with new ones.
- 5. Check rear shell bearing for signs of wear (excessive mix leakage in rear drip pan) and be certain it is properly cleaned.
- 6. Using a screwdriver and cloth towel, keep the rear shell bearing and the female drive socket clean and free of lubricant and mix deposits.
- 7. Follow all lubricating procedures as outlined in “Assembly”.
- 8. On air cooled units, Check the condensers and air filters for accumulation of dirt and lint. Dirty condensers or air filters will reduce the efficiency and capacity of the machine. Condensers and filters should be cleaned **monthly**. The air filters can be removed from the rear of the freezer and brought to the sink for cleaning. Use a soft brush to clean between the fins of the condensers. **Never** use screwdrivers or other metal probes to clean between the fins.
- 9. On water cooled units, check the water lines for kinks or leaks. Kinks can occur when the machine is moved back and forth for cleaning or maintenance purposes. Deteriorated or cracked water lines should be replaced only by an authorized Taylor mechanic.

Winter Storage

If the place of business is to be closed during the winter months, it is important to protect the freezer by following certain precautions, particularly if the building is to be left unheated and subject to freezing conditions.

Disconnect the freezer from the main power source to prevent possible electrical damage.

On water cooled freezers, disconnect the water supply. Use air pressure to blow out any water remaining in the condensers. **This is extremely important.** Failure to follow this procedure may cause severe and costly damage to the refrigeration system.

Your local Taylor Distributor can perform this service for you.

Wrap detachable parts of the freezer such as beater assembly and freezer door, and place in a protected dry place. Rubber trim parts and gaskets can be protected by wrapping with moisture-proof paper. All parts should be thoroughly cleaned of dried mix or lubrication accumulations which attract mice and other vermin.

Problem	Shake Side Probable Cause	Soft Serve Side Probable Cause	Either Side Probable Cause	Remedy	Page Ref.
1. All four LED's are flashing.			a. The freezer is locked.	a. See soft lock and hard lock information.	23
2. Soft lock message appears on LCD.			<p>a. More than 24 hours since the last HEAT cycle.</p> <p>b. The power switch is in the OFF position.</p> <p>c. The freezer was not in the AUTO or STANDBY mode.</p> <p>d. Mix out condition.</p>	<p>a. The freezer must go through a HEAT cycle every 24 hours. The freezer must now be disassembled and brush cleaned or placed in a heat cycle.</p> <p>b. The power switch must be in the ON position. The freezer must now be disassembled and brush cleaned or placed in a heat cycle.</p> <p>c. The freezer must be in the AUTO or STANDBY mode. Freezer must now be disassembled and brush cleaned or placed in a heat cycle.</p> <p>d. The level of mix in the mix hopper must be above the mix low probe. The freezer must now be disassembled and brush cleaned or placed in a heat cycle.</p>	19

Problem	Shake Side Probable Cause	Soft Serve Side Probable Cause	Either Side Probable Cause	Corrective Action	Page Ref.
2. Soft lock message appears on LCD. (<i>Cont'd.</i>)			<ul style="list-style-type: none"> e. The agitator is not installed. f. The agitator is not rotating. g. An equipment fault has occurred. 	<ul style="list-style-type: none"> e. The agitator must be cleaned and installed before starting the HEAT cycle. The freezer must now be disassembled and brush cleaned. f. The agitator must be cleaned before starting the HEAT cycle. Disassemble the freezer and brush clean. g. See Screen "H" in the Operator's Menu to determine the cause. 	43 43
3. Hard lock message appears on LCD.			<ul style="list-style-type: none"> a. A barrel or hopper thermistor is faulty. b. More than 14 days since the last brush cleaning. 	<ul style="list-style-type: none"> a. Call a service technician. b. The freezer must be disassembled and brush cleaned every 14 days. 	-- 57, 58
4. No product is being dispensed.			<ul style="list-style-type: none"> a. Low on mix. The MIX OUT light is ON. b. The power switch is in the OFF position. c. Freeze-up in mix inlet hole. 	<ul style="list-style-type: none"> a. Add mix to the mix hopper. b. Place the power switch to ON and press the AUTO keypad. c. Call service technician. 	39 35 --

Problem	Shake Side Probable Cause	Soft Serve Side Probable Cause	Either Side Probable Cause	Corrective Action	Page Ref.
4. No product is being dispensed. (Cont'd.)			<p>d. Beater motor is out on reset.</p> <p>e. Air/mix pump is incorrectly assembled or improperly lubricated.</p> <p>f. Missing or incorrectly installed spring and poppet in air/mix pump.</p> <p>g. The mix pump ball crank is broken.</p> <p>h. The pump motor is not activated.</p>	<p>d. Clear the tone. Allow the beater motor to cool. Place the power switch to OFF. Press the reset button firmly, place the power switch to ON and press the WASH keypad. Open the side access panel and observe that the drive shaft is turning CLOCKWISE as viewed from the front of the machine. Press the AUTO keypad to return to the AUTO mode. If the beater motor should go OFF on reset again, call service technician.</p> <p>e. Follow assembly procedures carefully.</p> <p>f. Replace or correctly install the spring and poppet on the mix inlet fitting.</p> <p>g. Call service technician.</p> <p>h. Push the reset button. The draw valve must be fully raised to activate the pump motor.</p>	<p>15</p> <p>31</p> <p>33</p> <p>--</p> <p>--</p>

Problem	Shake Side Probable Cause	Soft Serve Side Probable Cause	Either Side Probable Cause	Corrective Action	Page Ref.
5. The product is too thick.	a. Not enough syrup – 1 fl. oz. (30 ml.) in 5 seconds.		<ul style="list-style-type: none"> b. Insufficient mix in the freezing cylinder. c. Improper priming procedures. d. Air/mix pump incorrectly assembled. e. The viscosity control is set too cold. f. Freeze-up in mix inlet hole. 	<ul style="list-style-type: none"> a. Calibrate the syrups. Ensure the syrup tanks have an adequate syrup supply. b. Check the air/mix pump assembly. Mix inlet tube must be fully submerged in mix. c. Drain the freezing cylinder and re-prime the machine. d. Follow assembly procedures carefully. e. Call service technician. f. Call service technician. 	<p>48</p> <p>39</p> <p>39</p> <p>31</p> <p>---</p> <p>---</p>
6. Product is too soft.	a. Too much syrup – 1 fl. oz. (30 ml.) in 5 seconds.	b. Draw rate is set too fast.	<ul style="list-style-type: none"> c. Outdrawing capacity of freezing cylinder. d. Inadequate air space. e. Dirty condenser or air filters on air cooled units. 	<ul style="list-style-type: none"> a. Calibrate syrups. b. Adjust draw rate of 5 to 7-1/2 oz. (142 g. to 213 g.) of product by weight every 10 seconds. c. Continuous draw rate is approximately one 16 oz. (473 ml.) shake by volume every 15-20 seconds (15 cones). d. Minimum of 3" (76 mm) of clearance around all sides. e. Clean regularly. 	<p>48</p> <p>15</p> <p>---</p> <p>2</p> <p>61</p>

Problem	Shake Side Probable Cause	Soft Serve Side Probable Cause	Either Side Probable Cause	Corrective Action	Page Ref.
6. Product is too soft. (Cont'd.)			f. Inadequate water supply on water cooled units. g. Bad scraper blades. h. The viscosity control is set too warm.	f. Check the water supply. Check the water lines for leaks or kinks. g. Replace the scraper blades. h. Call service technician.	61 75 - - -
7. The mix in hopper is too warm.			a. Hopper cover is not in position. b. The agitator is not installed. c. The hopper temperature is out of adjustment.	a. Clean the hopper cover and place in position. b. Clean the agitator and install. c. Call service technician.	41 41 - - -
8. The mix in hopper is too cold.			a. The hopper temperature is out of adjustment.	d. Call service technician.	- - -
9. Product is collecting on top of draw valve.	a. Inadequate lubrication of spinner shaft or seal. b. Spinner shaft seal is missing or worn.			a. Lubricate properly. b. Install or replace the spinner shaft seal.	25 25
10. Product is collecting on top of the freezer door.			a. The top o-ring on draw valve is improperly lubricated or worn.	a. Lubricate properly or replace the o-ring.	25

Problem	Shake Side Probable Cause	Soft Serve Side Probable Cause	Either Side Probable Cause	Corrective Action	Page Ref.
11. Excessive mix leakage from the bottom of door spout.			<ul style="list-style-type: none"> a. Bottom o-ring on draw valve is improperly lubricated or worn. 	<ul style="list-style-type: none"> a. Lubricate properly or replace the o-ring. 	25
12. Excessive mix leakage into the long drip pan.			<ul style="list-style-type: none"> a. The seal on drive shaft is improperly lubricated or worn. b. The seal is installed inside-out on the drive shaft. c. Worn or missing o-rings on pump drive shaft. d. Inadequate lubrication of the drive shaft. e. The drive shaft and beater assembly work forward. f. Worn rear shell bearing. g. Gear box out of alignment. 	<ul style="list-style-type: none"> a. Lubricate properly or replace the seal. b. Install correctly. c. Install or replace the o-rings. d. Lubricate properly. e. Call service technician. f. Call service technician. g. Call service technician. 	<p>25</p> <p>---</p> <p>25</p> <p>25</p> <p>---</p> <p>---</p> <p>---</p>

Problem	Shake Side Probable Cause	Soft Serve Side Probable Cause	Either Side Probable Cause	Corrective Action	Page Ref.
13. The drive shaft is stuck in the drive coupling.			<ul style="list-style-type: none"> a. Mix and lubricant collected in drive coupling. b. Rounded corners of drive shaft, drive coupling or both. c. Gear box is out of alignment. 	<ul style="list-style-type: none"> a. Brush clean the rear shell bearing area regularly. b. Call service technician. c. Call service technician. 	59 - - - - - -
14. Freezing cylinder walls scored.	<ul style="list-style-type: none"> b. Broken beater pins. 	<ul style="list-style-type: none"> c. Beater assembly is bent. 	<ul style="list-style-type: none"> a. Missing or worn front bearing. d. Gear box is out of alignment. 	<ul style="list-style-type: none"> a. Install or replace the front bearing. b. Repair or replace the beater assembly. When installing scraper blades, be sure they are properly attached over the pins. c. Beater assembly must be replaced. Call service technician to correct cause of bent beater assembly. d. Call service technician. 	24 - - - - - -

Problem	Shake Side Probable Cause	Soft Serve Side Probable Cause	Either Side Probable Cause	Corrective Action	Page Ref.
15. Spinner shaft will not rotate to blend mix and syrup.	<ul style="list-style-type: none"> a. Flexible coupling is broken. b. Pin is missing in quick disconnect of spinner coupling. c. Spinner motor is out on thermal overload. 			<ul style="list-style-type: none"> a. Call service technician. b. Call service technician. c. Allow the spinner motor to cool. Also check lubrication on spinner shaft. Properly align the motor and lubricate properly. 	<p>---</p> <p>---</p> <p>26</p>
16. Large pressure adjustments are necessary to receive 1 fl. oz. (30 ml.) in 5 seconds.	<ul style="list-style-type: none"> a. Hardened syrup in syrup lines. b. Syrup and air lines are not matched. c. Plugged restrictor in vanilla or strawberry syrup line connection at the syrup tank. 			<ul style="list-style-type: none"> a. Clean and sanitize weekly. b. Match color spiral air and syrup line to correct syrup tank. c. Clean the restrictor. Remove the air line from the syrup tank. Remove the syrup line (vanilla or strawberry) from the syrup tank. Disassemble and pull the restrictor out of the female quick disconnect of the syrup line, and clean. 	<p>60</p> <p>47</p> <p>---</p>

Problem	Shake Side Probable Cause	Soft Serve Side Probable Cause	Either Side Probable Cause	Corrective Action	Page Ref.
16. Large pressure adjustments are necessary to receive 1 fl. oz. (30 ml.) in 5 seconds. (<i>Cont'd.</i>)	<ul style="list-style-type: none"> d. Plugged syrup line fitting at freezer door connection. e. Inadequate air pressure to syrup solenoids. 			<ul style="list-style-type: none"> d. Clean the syrup line fitting. e. Call service technician. 	- - -
17. Pump will not operate in the PUMP mode.			<ul style="list-style-type: none"> a. Pump motor is not activated. b. The membrane switch is defective. 	<ul style="list-style-type: none"> a. Push the reset button. b. Call service technician. 	- - -
18. Machine will not run when in the AUTO mode.			<ul style="list-style-type: none"> a. Machine is unplugged. b. Beater motor is out on reset. 	<ul style="list-style-type: none"> a. Plug into wall receptacle. b. Clear the tone. Allow the beater motor to cool. Place the power switch to OFF. Press the reset button firmly. Place the power switch to ON, and press the WASH keypad. Open the side access panel and observe that the drive shaft is turning CLOCKWISE as viewed from the front of the machine. Press the AUTO keypad to return to the AUTO mode. If the beater motor should go OFF on reset again, call service technician. 	- - - 15

Problem	Shake Side Probable Cause	Soft Serve Side Probable Cause	Either Side Probable Cause	Corrective Action	Page Ref.
18. Machine will not run when in the AUTO mode. (Cont'd.)			<ul style="list-style-type: none"> c. Circuit breaker OFF or blown fuse. d. Low on mix. The MIX OUT light is ON. e. Water is turned OFF on water cooled units. 	<ul style="list-style-type: none"> c. Turn the breaker ON or replace the fuse, and clear the fault. d. Add mix to the mix hopper and press the AUTO keypad. e. Turn water ON, and clear the fault. 	<p>---</p> <p>39</p> <p>---</p>
19. Air compressor runs too often for normal usage.	<ul style="list-style-type: none"> a. Air leak in the system. 			<ul style="list-style-type: none"> a. Use a soap solution to locate the leak and repair. 	<p>---</p>
20. Liquid Crystal Display is blank.			<ul style="list-style-type: none"> a. Machine is unplugged. b. Circuit breaker is OFF or blown fuse. c. Component failure. d. LCD intensity needs adjusting. 	<ul style="list-style-type: none"> a. Plug into wall receptacle. b. Turn the circuit breaker ON or replace the fuse, and clear the fault. c. Call service technician. d. Call service technician. 	<p>---</p> <p>---</p> <p>---</p> <p>---</p>
21. Product is not feeding into the freezing cylinder.			<ul style="list-style-type: none"> a. The mix inlet hole is frozen up. 	<ul style="list-style-type: none"> a. The hopper temperature needs adjustment. Call service technician. 	<p>---</p>
22. The draw handle does not close.	<ul style="list-style-type: none"> a. Mix is on the sensing eye. 			<ul style="list-style-type: none"> a. Clean the sensing eye. 	<p>---</p>

Problem	Shake Side Probable Cause	Soft Serve Side Probable Cause	Either Side Probable Cause	Corrective Action	Page Ref.
23. Syrup toppings are not hot.		<ul style="list-style-type: none"> a. No water is in topping well. b. The water is not hot enough. 		<ul style="list-style-type: none"> a. Fill to indicating mark. b. Using a thermometer, check the water temperature in the topping well. It should be 140° F. (60° C.). Open the side access panel and turn the thermostat screw CLOCKWISE in small increments. Allow sufficient time to recheck the water temperature. 	44 - - -
24. Product “popping” when drawn.		<ul style="list-style-type: none"> a. Draw rate set too fast. 	<ul style="list-style-type: none"> b. Pump assembled incorrectly. 	<ul style="list-style-type: none"> a. The draw rate should be set at 5 to 7-1/2 oz. of product per 10 seconds. b. Assemble and lubricate according to instructions in this manual. 	15 31
25. Freezer shuts off, but fault tone continues.			<ul style="list-style-type: none"> a. Fault has occurred in the freezer. b. Inadequate air clearance around the freezer. 	<ul style="list-style-type: none"> a. Verify condition in the Operator’s Menu “fault” screen. Clear fault accordingly. b. Maintain 3” (76 mm) of space around all sides of the unit. 	20 2
26. Syrup flows constantly, or not at all. Difficult to calibrate syrups.	<ul style="list-style-type: none"> a. Syrup lines are clogged. 		<ul style="list-style-type: none"> b. Diaphragm is faulty. 	<ul style="list-style-type: none"> a. Flush syrup lines with warm water and sanitize weekly. b. Clean or replace the diaphragm syrup fitting. 	60 48

Problem	Shake Side Probable Cause	Soft Serve Side Probable Cause	Either Side Probable Cause	Corrective Action	Page Ref.
27. Pump parts difficult to assemble.			a. Shake and soft serve pump components are intermixed.	a. Verify proper pump components.	11
28. Mix low and mix out probes are not functioning.			a. Milkstone build-up in the hopper.	a. Clean hoppers thoroughly.	35

Section 9

Parts Replacement Schedule

PART DESCRIPTION	EVERY 3 MONTHS	EVERY 6 MONTHS	ANNUALLY
Scraper Blade-Shake		X	
Scraper Blade-Soft Serve	X		
Drive Shaft Seal	X		
Freezer Door O-Ring-Shake	X		
Freezer Door Gasket-Soft Serve	X		
Front Bearing	X		
Beater Front Shoes-Soft Serve	X		
Draw Valve O-Ring	X		
Spinner Shaft Seal-Shake	X		
Pivot Pin O-Ring	X		
Design Cap-Soft Serve	X		
Restrictor Cap-Shake	X		
Mix Feed Tube O-Ring	X		
Pump O-Ring	X		
Pump Check Ring	X		
Spring	X		
Rubber Poppet	X		
Mix Inlet Tube O-Ring	X		
Air Inlet Fitting Seal	X		
Pump Drive Shaft O-Ring	X		
Pump Drive Shaft Cup Seal	X		
White Bristle Brush, 3" x 7"		Inspect & Replace if Necessary	Minimum
White Bristle Brush, 3" x 1/2"		Inspect & Replace if Necessary	Minimum
White Bristle Brush, 1-1/2" x 2"		Inspect & Replace if Necessary	Minimum
White Bristle Brush, 1" x 2"		Inspect & Replace if Necessary	Minimum
Black Bristle Brush, 1" x 2"		Inspect & Replace if Necessary	Minimum
Double-Ended Brush		Inspect & Replace if Necessary	Minimum
Door Spout Brush		Inspect & Replace if Necessary	Minimum
Syrup Port Brush		Inspect & Replace if Necessary	Minimum

Section 10

Parts List

DESCRIPTION	PART NUMBER	QTY.	WARR. CLASS	REMARKS	PARTS UPDATE
ACCUMULATOR A.-AIR *5472*PRTL	X46916	1	103		
FITTING A.-AIR ACCUMULATOR	X48548	1	103	J5010000/UP	90
+TUBE-VINYL 1/8 ID X 1/16 WALL	020938-6	1	000	BULK UNDER P/N R30301	
+VALVE-SOLENOID	044125-27	1	103		
ACCUMULATOR A.-GLYCOL	X44055	1	103	J4019999/PRIOR (NEW - SEE TANK-GLYCOL)	79
AGITATOR A. *HT*20 QT HOPPER	X44797	2	103		
BAFFLE A.-BLOWER-LESS MESH	X23412-SP	1	103	J4047459/PRIOR (NEW - SEE DEFLECTOR)	80
BEARING-FRONT	050348	1	000	SOFT SERVE - W/FRONT SHOES (X50350)	
BEARING-FRONT 2"OD X .688 ID	051165	1	000	SHAKE	
BEARING-REAR SHELL *NICK.PLATE	031324	2	000		
+GUIDE-DRIP SEAL	028992	2	000		
+NUT-BRASS BEARING	028991	2	000		
+WASHER-BEARING LOCK	012864	2	000		
BEATER A.-3.4QT-1 PIN-SUPPORT	X46231	1	103	SOFT SERVE	
+BLADE-SCRAPER-PLASTIC 8-1/8L	046235	2	000		
+CLIP-SCRAPER BLADE	046236	2	103		
BEATER A.-7QT-FLUTED BLADE	X50958	1	103	SHAKE (REPLACES X42315) USE W/ 050985 SHAFT-BEATER	113
+BLADE-SCRAPER	041103	2	000		
BELT-RD 3/16 W X 5.35 ID	044007	1	000	SHORT	
BELT-RD 3/16 W X 9.12 ID	039108	1	000	LONG	
BELT-AX30	052191	1	000	SHAKE - J8040000/UP	129
BELT-V-4L320	023862	1	000	SHAKE - J8039999/PRIOR	129
BELT-AX33	024396	2	000	SOFT SERVE	
BLADE A.-SPINNER-ALUMINIUM-HT	X41895	1	103		
BLOCK-TERMINAL 3P	039423	1	103		
BLOCK-TERMINAL 5 POLE	024329	2	103		
BLOCK-TERMINAL-PLUG 10P .2 SIP	040322-005	2	103		
BLOCK-TERMINAL-PLUG 6P .2 SIP	040322-002	1	103		
BLOCK-TERMINAL-PLUG 7P .2 SIP	040322-003	4	103		

+ Available Separately

DESCRIPTION	PART NUMBER	QTY.	WARR. CLASS	REMARKS	PARTS UPDATE
BLOCK-TERMINAL-PLUG 8P .2 SIP	040322-004	2	103		
BLOWER A.-HIGH OUTPUT	X53478-27	1	103	J9110000/UP	148
CAPACITOR-RUN- 10 UF/370V	033047	1	103		148
CLIP-SCREEN-BLOWER	053730	1	103	J9110000/UP	148
HOUSING-BLOWER-4 POLE	053727	1	103	J9110000/UP	148
MOTOR-BLOWER FAN HIGH OUTPUT	053480-27	1	103	J9110000/UP	148
SCREEN-BLOWER	053730	1	103	J9110000/UP	148
BLOWER A.	X47833-	1	103	J4047460-J9110000 HP62	80, 148
BOOT-CAPACITOR INSULATING	031314	1	000	J4047460-J9110000 HP62	80, 148
CAPACITOR-RUN- 10 UF/370V	033047	1	103	J4047460 HP62	80, 148
HOUSING A.-W/WHEEL	X30160-SER	1	103	J9110000/PRIOR	148
MOTOR-BLOWER-208/230V 50/60 HZ	046536-	1	103	J4047460-J9110000 HP62 MAY UPDATE W/ X53763- KIT A-MOTOR-BLOWER HIGH OUTPUT	80, 148
BLOWER A.	X30153-	1	103	J4047459/PRIOR	80
HOUSING A.-W/WHEEL	X30160-SER	1	103		
MOTOR-BLOWER FAN 230V	030157-	1	103	J4047459/PRIOR	80
BOTTLE A.-SQUEEZE *5472*	X45080	1	000		
BRUSH A.-PACKAGE*HT*	X44127	1	000		
BRUSH-1/2 IN. DIA.	033059	1	000		
BRUSH-DOUBLE ENDED-PUMP&FEED T	013072	1	000		
BRUSH-DRAW VALVE 1"ODX2"X17"L	013073	1	000		
BRUSH-DRAW VALVE 1-1/2"OD X 3"	014753	1	000		
BRUSH-END-DOOR-SPOUT-SS-HT	039719	1	000		
BRUSH-MIX PUMP BODY-3"X7"WHITE	023316	1	000		
BRUSH-PUMP SPOUT *MC13*	054068	1	000		
BRUSH-REAR BRG 1IN.DX2IN.LGX14	013071	1	000		
BRUSH-SYRUP PORT	050103	1	000	Includes 045079 Syrup Port Brush	
BRUSH-PUMP VALVE BODY	054068	1	000		149
CABINET A.-SYRUP *8634*	X45720	1	103	J6050000/UP - NEW DESIGN	112
CABLE-RIBBON-10C-5"L-DIL/DIL	040040-024	1	103	LED TO LED	
CABLE-RIBBON-10C-73"DIL/DIL	040040-030	1	103	J3-IF SOFT SERVE TO LED	

+ Available Separately

DESCRIPTION	PART NUMBER	QTY.	WARR. CLASS	REMARKS	PARTS UPDATE
CABLE-RIBBON-14C-14"L SIP/SIPR	040040-015	1	103	J9-UC TO LCD	
CABLE-RIBBON-20C-78"R DIL/DIL	040040-032	1	103	J2-UC TO J12-IB SHAKE	
CABLE-RIBBON-20C-9"DIL/DIL	040040-031	1	103	J12-IB SOFT SERVE TO J11-IB SHAKE	
CABLE-RIBBON-20D-82"R DIL/DIL	040040-033	1	103	J7-UC TO J9-IB SHAKE	
CABLE-RIBBON-50C-65"DIL/DIL	040040-034	1	103	J11-UC TO J2-IB SOFT SERVE	
CABLE-RIBBON-50C-76"DIL/DIL	040040-035	1	103	J10-UC TO J2-IB SHAKE	
CABLE-2 COND #22 SHIELDED	045154-75	1	103	POWER CABLE IB-UC (BULK P/N R6003003)	
CAP A.-DRAW VALVE-INSULATED	X41902	1	103		
+O-RING-1-11/16 OD X.139W	041923	1	000		
CAP-DESIGN-1.010"ID-6 POINT	014218	1	000	SOFT SERVE	
CAP-RESTRICTOR	033107	1	000	SHAKE	
CAPACITOR-RUN- .8UF/400V	039482	1	103	AGITATOR MOTOR	
CAPACITOR-RUN- .3UF/550 V	035342-	1	103	SPINNER MOTOR	
CAPACITOR-START- 47-56UF/220 TO 250V	037251-34	1	103	SOFT SERVE MOTOR REDUCER	
CARD-DAILY CLEAN-HT-COMBO	046705	1	000		
CASTER-SWV-3/4-10 ST. 4IN WHL	044106	4	103		
CLAMP-HOSE 9/16 CRIMP TYPE	047344	25	000	GLYCOL LINES	
COLLAR-HOLDING	019481	5	103	CONE/CUP DISPENSER	
COMPRESSOR A.-AIR *8634*	X46982-SER	1	103		
COMPRESSOR-AIR	032129-27	1	103		
CROSS-1/4 FPT	077339	1	000		
FITTING-1/4MPT X .170BARB STR	075880	1	000		
GAUGE-PRESSURE 0-60 PSI 1/4MPT	046933	1	103		
NIPPLE-1/4IPT X 7/8LONG BRASS	026496	1	000		
SWITCH-PRESSURE	016308	1	103		
VALVE-CHECK 1/4MP	020959	1	103		
COMPRESSOR AH2490Z-AH556RT - SOFT SERVE	047519-	1	512	J4047460/UP HP62 (FRENCH BUIL T-J9090000/UP)	80/146
+GROMMET-COMPRESSOR MOUNTING	039923	4	000	J4047460/UP HP62	80
+SLEEVE-COMP. MOUNTING	039924	4	000	J4047460/UP HP62	80
COMPRESSOR L53A113DBLA - SOFT SERVE	038144-	1	512	J4047459/PRIOR	80

+ Available Separately

DESCRIPTION	PART NUMBER	QTY.	WARR. CLASS	REMARKS	PARTS UPDATE
+GROMMET-COMPRESSOR MOUNTING	037428	4	000	J4047459/PRIOR	80
+SLEEVE-COMP. MOUNTING	037429	4	000	J4047459/PRIOR	80
COMPRESSOR AH7513Z-AH245RT - SHAKE	047520-	1	512	J4047460/UP HP620 (FRENCH BUILT-J9090000/UP)	80/146
+GROMMET-COMPRESSOR MOUNTING	039923	4	000	J4047460/UP HP62	80
+SLEEVE-COMP. MOUNTING	039924	4	000	J4047460/UP HP62	80
COMPRESSOR M51B143DBLA - SHAKE	036880-	1	512	J4047459/PRIOR	80
+GROMMET-COMPRESSOR MOUNTING	037428	4	000	J4047459/PRIOR	80
+SLEEVE-COMP. MOUNTING	037429	4	000	J4047459/PRIOR	80
CONDENSER-AC-12LX18HX4.3-5ROW	019558	2	103		
COUPLING A.-DRIVE-SPINNER	X20329	1	103		
+PIN-ROLL-.094D X .562L	015971	1	000		
COUPLING A.-TORQUE-SHAKE (OLD)	X41069	1	103	PRIOR TO J4010000	114
COUPLING A.-TORQUE-SHAKE	X52620	1	103	J4010000 - USE X52620 (Replaces X46868)	132
PIN-COUPLING-TORQUE	039453	3	103		
PIN-STOP-TORQUE COUPLING-.725L	042312	3	103		
SCREW-5/16-18 X 3/8 ALLEN SET	025376	2	000		
SCREW-SHOULDER 3/16D X 1/2L-SS	039455	3	000		
SPRING-3/8 ODX3/16 IDXIL-GOLD	052476	3	103		132
COUPLING-DRIVE 3/4 HEX X 1-7/8	012721	1	103	SOFT SERVE	
+SCREW-5/16-18 X 5/16 ALLEN SET	042511	2	000		
COUPLING-FLEXIBLE W/SCREWS	020108	1	103		
COVER A.-HOPPER INS.-COMPLETE	X42628-SER	2	103		
KNOB-MIX COVER	025429	1	103		
+PIN-RETAINING-HOPPER COVER	043934	2	103		
RETAINER-HOPPER COVER	042619	2	103		
SCREW-8-32 X 1/2 OVAL HD-SS	043295	8	000		
CUP-DIVIDED SYRUP	017203	1	000		
CYLINDER-AIR 1-1/6 BORE X 1 IN	032999	1	103		
+SCREW-8-32 X 1/4 ALLEN SET	043603	1	000		
+CAP-AIR CYLINDER *PORTION CTRL	045975	1	103		

+ Available Separately

DESCRIPTION	PART NUMBER	QTY.	WARR. CLASS	REMARKS	PARTS UPDATE
DECAL-DAILY CLEANING-HT COMBO	045272	1	000		
DECAL-DEC-TAYLOR-PH90	052282	1	000	J8070000/UP (ON POSITION - RIGHT SIDE)	132
DECAL-DEC-TAYLOR-PH90	046179	1	000	PRIOR TO J8070000	132
DECAL-MAG-CLOSING CHECKLIST	044309	1	000		
DECAL-MANUAL CLEANING-HT COMBO	045275	1	000		
DECAL-OVERLOAD SETTING	045384	1	000		
DECAL-SET 4 SYRUP FLAVOR	021523	1	000		
DECAL-SET-SYRUP VALVES	045521	1	000		
DECAL-SYRUP COMPARTMENT	021571	1	000		
DECAL-SYRUP FLAVOR INSTRUCTION	020997	1	000		
DECAL-SYRUP TANK INSTRUCTION	045533-1	4	000		
DECAL-TROUBLESHOOTING	038374	1	000		
DEFLECTOR-BLOWER EXHAUST	047912	1	103	J4047460/UP HP62	80
DIAGRAM-WIRING *8634*PH90	047984-	1	000		
DISPLAY-LIQUID CRYSTAL	X38062-SER	1	103		
+LENS-DISPLAY	038221	1	103		
+STANDOFF-LENS	038225	4	000		
DOOR A.-HT-1SPT-4 FLV-SHAKE	X50701-1	1	103	SHAKE	
+HANDLE-DRAW VALVE *8663*	034003	1	103		
+O-RING-6 IN ODX5 3/4 IDX 1/8	033493	1	000	(DOOR GASKET)	
+PIN A.-PIVOT	X22820	1	103		
+O-RING-5/16 OD X .070W	016272	1	000		
+VALVE A.-DRAW-ALUMINUM *5472HT	X42210	1	103		
+O-RING-1-1/16 OD X.139W	020571	2	000		
DOOR A.-1 SPOUT	X51531-9	1	103	J5080000/UP SOFT SERVE	96
DOOR A.-1 SPOUT				J5080000/PRIOR SEE KIT A.-DOOR	
+GASKET-DOOR-HT-4" SHELL	048926	1	000		
+HANDLE A.-DRAW-ADJ. *8634*	X44212	1	103		
O-RING-1/4 OD X .070W 50 DURO	015872	1	000		
SCREW-ADJUSTMENT-5/16-24X1-1/	033662	1	000		
+NUT-5/16-24 18-8 SS JAM	029639-BLK	1	000		

+ Available Separately

DESCRIPTION	PART NUMBER	QTY.	WARR. CLASS	REMARKS	PARTS UPDATE
+PIN A.-PIVOT	X22820	1	103		
+O-RING-5/16 OD X .070W	016272	1	000		
+VALVE A.-DRAW*SELF CLEANING*	X33582	1	103		
+O-RING-7/8 OD X .103W	014402	3	000		
DOOR A.-SYRUP CABINET *8634*LEFT	X45726	1	103		
DOOR A.-SYRUP CABINET *8634*RIGHT	X45729	1	103		
DRYER-FILTER-HP62-3/8 X 1/4S	048901	2	000	J4047460/UP HP62 (J7090000/REPLACES 047521)	80-121
DRYER-FILTER 3/8 X 1/4 SOLDER	045866	1	000	J4047459/PRIOR	80
FILTER-AIR 13.5X17.75X7/16	042703	2	000		
FILTER-CORCOM 6EH1	040140-001	1	103		
FILTER-INLINE-GLYCOL-40 MICRON	041670	1	000		
+ARMAFLEX-BOOT 1-3/8 ID X 3/8 W	047490	1	000		
FLUID A.-HEAT TRANSFER	X39667	1	000	1 GALLON	
FUSE-15 AMP-IN LINE-NON DELAY	045293	2	000		
HOLDER-FUSE-IN LINE-TYPE HLR	045606	2	103		
GEAR A.*REDUCER	021286	2	212		
GEAR A.*REDUCER-AGITATOR	047988	1	103		
GUARD-POWER SWITCH	034830	1	103		
GUIDE A.-DRIP PAN - RIGHT	X51625	1	103	J7120000/UP SIDE MOUNT (OLD GUIDE 044043)	125
GUIDE A.-DRIP PAN-LEFT	X51628	1	103	J7120000/UP SIDE MOUNT (OLD GUIDE 044043)	125
GUIDE A.-DRIP PAN *8634 HT*	X44041	1	103	FRONT PANEL-REAR SHELL BEARING	
GUIDE A.-DRIP PAN-MIX PUMP	X48228	2	103	REAR PANEL-MIX PUMP	84
HANDLE-STNLS FLUSH PULL	019043	2	103		
HEATER A.-GLYCOL-4500 W-PRTL	X47395-	1	103	J4020000/UP	79
HEATER A.-GLYCOL-4500 W-PRTL	X42729-	1	103	J4019999/PRIOR	79
THERMOSTAT-HI LIMIT	035786	1	103		
HINGE A.-DOOR *8634*RIGHT	X45736	2	103		
HINGE A.-DOOR *8634*LEFT	X45741	2	103		
HINGE A.-MOTOR MOUNT RIGHT	X25703	1	103	J8039999/PRIOR	129
HINGE A.-MOTOR MOUNT RIGHT	X25731	1	103	J8040000/UP	129

+ Available Separately

DESCRIPTION	PART NUMBER	QTY.	WARR. CLASS	REMARKS	PARTS UPDATE
HINGE A.-MOTOR MOUNT LEFT	X25736	1	103		
HINGE A.-PIN *8634*RIGHT	X45739	2	103		
HINGE A.-PIN *8634*LEFT	X45743	2	103		
HOLDER A.-SENSOR ADJUSTABLE	X51464	1	103	J7120000/UP	125
BRACKET A.-SENSOR	X51465	1	103		
+COVER-SENSOR	051467	1	103	SEPARATE ITEM	125
HOLDER-SENSOR-PYROELECTRIC	038978	1	103		
NUT-LOCK 5/16-18 ss	043072	1	000		
PIN-GUIDE 5/16 OD X 1-5/16 LONG	038980	2	103		
SCREW 10-32 X 9/16 DOG PT SET	038981	2	000		
SCREW-8-32 X 5/16 RD HD STNL	017552	2	000		
SCREW-ADJUSTMENT 5/16-18	051574	1	000		
HOLDER A.-SENSOR ADJUSTABLE (OLD)	X38976	1	103	PRIOR TO J7120000	125
GUIDE A.-SENSOR-ADJUSTABLE	X39176	1	103		
HOLDER-SENSOR-PYROELECTRIC	038978	1	103		
KNOB A.-ADJUSTMENT-POROTION CTL	X43231	1	103		
SCREW-10-32X9/16 DOG PT SET	038981	2	103		
SCREW-ADJUSTMENT-5/16-18	038984	1	103		
HOLDER-CUP-SHAKE-3.906" DIA	046939	1	103	J4110000/UP (ADJUSTABLE)	88
+CLIP-SPRING-CUP HOLDER	046940	2	103	J4110000/UP	88
HOLDER-CUP-SHAKE	038985	1	103	J4109999/PRIOR	88
HOSE-RUBBER 5/16" X 9/16"OD	047340-	16FT	000	BULK P/N R502011 FOR GYLCOL SYSTEM	
HOUSING A.-AGITATOR *HT*	X51664	1	103	SHAKE	
+CAP-MAGNET *HT*	044796	1	103		
MAGNET A.-AGITATOR-INNER	X41733	1	103		
HOUSING-A.-AGITATOR *751-754*	X51661	1	103	SOFT SERVE	
+CAP-MAGNET *HT*	044796	1	103		
MAGNET A.-AGITATOR-INNER	X41733	1	103		
JAR-SYRUP-PLASTIC	036573	2	103		
JAR-SYRUP-STAINLESS-SHALLOW	036574	2	103		

+ Available Separately

DESCRIPTION	PART NUMBER	QTY.	WARR. CLASS	REMARKS	PARTS UPDATE
KIT A.-DOOR 1 SPOUT FIELD REPLACEMENT	X51531-1	1	103	MUST USE ON UNITS BEFORE S/N J5080000 TO REPLACE X45156-SER DOOR ASSY.	96
BEARING-FRONT	050348	1	000		
DOOR-1 SPOUT	X51531-9	1	103	SOFT SERVE - W/FRONT SHOES (X50350-KIT)	
GASKET-DOOR HT 4"-DOUBLE	048926	1	000		
NUT-STUD FLAT END-1-3/8 LONG	021508	4	103		
O-RING-7/8 OD X .103W	014402	3	000		
KIT A.-SYRUP VALVE MEAD UPDATE	X50644	1	103	REPLACES 045787	
KIT A.-TOPPING PUMP SPARES	X53795	1	000		
SEAL A.	X33057	2	000		
O-RING-9/16 OD X .103W	016369	2	000		
WASHER-NYLON	032760	2	000		
BRUSH-1/2 IN. DIA.	033059	1	000		
O-RING-1 OD X .103W	048148	2	000		
O-RING-1-5/16 OD X.103W	048149	2	000		
BRUSH-PUMP VALVE BODY	054068	1	000	REPLACES X45144	148
KIT A.-TUNE UP-1 SPOUT	X49463-12	1	000		
BEARING-FRONT	050348	1	000	SOFT SERVE - W/FRONT SHOES (X50350-KIT)	
BEARING-FRONT 2"OD X .688 ID	051165	1	000	SHAKE	
CAP-DESIGN-1.010"ID-6 POINT	014218	1	000	SOFT SERVE	
CAP-RESTRICTOR	033107	1	000	SHAKE	
GASKET-DOOR HT 4"-DOUBLE	048926	1	000	SOFT SERVE	
O-RING 1/2 ID X .139W-206	048632	4	000	MIX PUMP DRIVE SHAFT	
O-RING-1-1/16 OD X.139W	020571	3	000	SHAKE DRAW VALVE	
O-RING-1-11/16 OD X.139W	041923	1	000	DOOR SPOUT CAP	
O-RING-1-3/4 OD X .139W	008904	2	000	MIX PMP DR SHFT	
O-RING-1-3/8 OD X .103W	018664	2	000	LIQUID VALVE BODY	
O-RING-1/2OD X .070W	024278	8	000	SYRUP LINE FITTING	
O-RING-11/16ODX.103W-RED	016132	4	000	MIX FEED TUBES	
O-RING-2-1/8 OD X .139W	020051	8	000	LIQUID VALVE BODY & PISTON	

+ Available Separately

DESCRIPTION	PART NUMBER	QTY.	WARR. CLASS	REMARKS	PARTS UPDATE
O-RING-3/4 OD X .103W	015835	2	000	MIX INLET TUBE	
O-RING-5/16 OD X .070W	016272	2	000	PIVOT PIN	
O-RING-6 IN ODX5 3/4 IDX 1/8	033493	1	000	SHAKE DOOR	
O-RING-7/8 OD X .103W	014402	3	000	SOFT SERVE DRAW VALVE	
POPPET-RUBBER-BLACK	022473	2	000		
RING-CHECK 1-1/4 OD X 3/8	033215	2	000	LIQUID VALVE BODY	
RING-CHECK 2 IN OD X 1/2	020050	4	000	LIQUID VALVE BODY	
SEAL-AIR INLET FITTING	045327	2	000		
SEAL-DRIVE SHAFT	032560	2	000	DRIVE SHAFT	
SEAL-SPINNER SHAFT	036053	1	000		
TOOL- O-RING REMOVAL	048260-WHT	1	000		
LABEL-CAUTION-AGITATOR	045191	2	000		
LABEL-DOOR-WARN-MOVE PART	032749	1	000		
LABEL-RESET-MIX PUMP	044452	2	000		
LABEL-WARN-COVER	051433	5	000		
LADLE-1 OZ-120D BEND IN HANDLE	033637-1	2	103		
LID-SYRUP JAR	042706	2	103		
LINE A.-AIR *8634*	X47014	1	103		
COUPLING-5/32 BARB X 1/4 BARB	046980	1	103		
FERRULE-.475 ID NP BRASS	021082	2	000		
SOCKET-Q.D. CO2 90DEG 1/4BARB	021524	1	103		
TUBE-.170 ID X .250 OD	075885-8	1	000	BULK UNDER P/N R40302	
TUBE-NYLOBRADE 1/4ID X 7/16OD	020568-38	1	000	BULK UNDER P/N R30317	
LINE A.-SYRUP TWIN TUBE	X53399-88	4	103	J9096706/UP (REPLACES X45322-88)	145/146
FERRULE-.475 ID NP BRASS	021082	4	000		
FITTING-SYRUP VALVE	053397	4	103		
O-RING-1/2OD X .070W	024278	4	000		
TUBE-TWINNED 88"	045359	4	000		
CLAMP-TWINNED TUBE	052079	8	000		
LIP-DRIP-NOSE CONE	036435	2	000		
LOUVER-SIDE	013631	1	103	RIGHT SIDE	

+ Available Separately

DESCRIPTION	PART NUMBER	QTY.	WARR. CLASS	REMARKS	PARTS UPDATE
LOUVER-SIDE	028288	1	103	LEFT SIDE	
LUBRICANT-TAYLOR HI PERF-4 OZ	048232	1	000		
MAN-OPER PH90	047772-M	1	000		
MANIFOLD A.-REGULATOR *8634*	X46983	1	103		
DECAL-FLAVOR COLOR SET '4'	022105	1	000		
GAUGE-PRESSURE 0-60 PSI 1/8MPT	027875	4	103		
LINE A.-AIR 45 DEG BARB	X47043-12	4	103		
FERRULE-.475 ID NP BRASS	021082	2	000		
TUBE-NYLOBRADE 1/4ID X 7/16OD	020568-12	1	000	BULK UNDER P/N R30317	
NIPPLE-1/4IPT X 7/8LONG BRASS	026496	2	000		
PLUG-Q.D. CO2 1/8 MP	021077	1	103		
REGULATOR-PRESSURE-CO2	027744	5	103		
VALVE-PRESSURE RELIEF-45#	047252	1	103		
MANIFOLD-FIVE VALVE (OLD)	045787	1	103	SEE REPLACEMENT KIT - X50644	107
VALVE-AIR-3 WAY 24VAC	045787-1	4	103	FOR SERVICE - USE W/OLD STYLE 045787 ONLY	
VALVE-AIR-3 WAY 12VDC	045787-2	1	103	FOR SERVICE - USE W/OLD STYLE 045787 ONLY	
GASKET-3 WAY AIR VALVE	045787-3	5	000	FOR SERVICE - USE W/OLD STYLE 045787 ONLY	
MOTOR A.-SPINNER W/PLUG	X35584-27	1	103		
CONNECTOR-PLUG 3 PIN FEMALE	022522	1	103		
MOTOR-SPINNER-1/8 HP-3250 RPM	035341-27	1	103		
PIN-MALE .084"DIA-MATE-N-LOK	021624	3	103		
MOTOR-1.0 HP	013102-	1	212	SHAKE	
MOTOR-1.5 HP	021522-	1	212	SOFT SERVE	
MOTOR-AGITATOR	047987-	1	103		
MOTOR-REDUCER 108RPM-SHK-HT	044723-27	1	103	SHAKE (60Hz ONLY)	
COUPLING-MOTOR-FLEXIBLE	047936	2	103		86
GEAR-ONLY	049243-27	1	103	(60Hz)	93
MOTOR-ONLY	049242-27	1	103	(60Hz)	93
SEAL-MOTOR REDUCER-INPUT SHAFT	048836	2	000		90
SEAL-MOTOR REDUCER-OUTPUT SHAFT	048837	2	000		90
MOTOR-REDUCER 32 RPM-HPR PUMP	036955-34	1	103	SOFT SERVE (50 & 60Hz)	

+ Available Separately

DESCRIPTION	PART NUMBER	QTY.	WARR. CLASS	REMARKS	PARTS UPDATE
COUPLING-MOTOR-FLEXIBLE	047936	2	103		86
GEAR-ONLY	049247-34	2	103	(50 & 60Hz)	93
MOTOR-ONLY	049246-34	2	103	(50 & 60Hz)	93
SEAL-MOTOR REDUCER-INPUT SHAFT	048836	2	000		90
SEAL-MOTOR REDUCER-OUTPUT SHAFT	048837	2	000		90
NUT-STUD *482-5461-8663*	034034	4	103	SHAKE DOOR	
NUT-STUD *GENERAL USAGE*	021508	4	103	SOFT SERVE DOOR	
NYLON-SPIRAL WRAP-BLUE-2"	041582-4	2	000	BULK UNDER P/N R40336	
NYLON-SPIRAL WRAP-BROWN-2"	041582-1	2	000	BULK UNDER P/N R40338	
NYLON-SPIRAL WRAP-RED-2"	041582-2	2	000	BULK UNDER P/N R40337	
NYLON-SPIRAL WRAP-WHITE-2"	041582-3	2	000	BULK UNDER P/N R40320	
O-RING-SILICONE-RED (SYRUP VALVE FTG.)	053398-RED	1	000	J9096706/UP (REPLACES 042503-RED SHROUD)	145/146
O-RING-SILICONE-BLU (SYRUP VALVE FTG.)	053398-BLU	1	000	J9096706/UP (REPLACES 042503-BLU SHROUD)	145/146
O-RING-SILICONE-WHT (SYRUP VALVE FTG.)	053398-WHT	1	000	J9096706/UP (REPLACES 042503-WHT SHROUD)	145/146
O-RING-SILICONE-BRN (SYRUP V ALVE FTG.)	053398-BRN	1	000	J9096706/UP (REPLACES 042503-BRN SHROUD)	145/146
OVERLOAD-T#2BM-KG-16-68	042005-34	1	103	SHAKE MOTOR REDUCER	
+NUT-OVERLOAD RESET	045026	1	C		
OVERLOAD-T#2BMAK38-71	044464	1	103	SOFT SERVE MOTOR REDUCER	
+NUT-OVERLOAD RESET	045026	1	000		
PAIL-MIX 10 QT.	013163	1	000		
PAN-DRIP 19-1/2 LONG	035034	1	103	REAR SHELL BEARING	
PAN-DRIP HT	048204	2	103	J4070000/UP MIX PUMP	84
PAN A.-DRIP*8634* HOPPER PUMP	X45289	2	103	J4070000/PRIOR MIX PUMP	84
PAN-DRIP 13-1/4" LG	051642	2	103	J7120000/UP BLACK PLASTIC - NOTCHED	125
PANEL A.-FRONT W/SYRUP RAIL	X51576	1	103	J7120000/UP (SEE SYRUP RAIL)	125
PANEL A.-FRONT *8634*	X45745	1	103	PRIOR TO J7120000	125
PANEL A.-SIDE *8634*LOWER LEFT	X46449-SER	1	103		
PANEL A.-SIDE *8634*LOWER RIGHT	X46450-SER	1	103		
PANEL A.-SIDE LEFT *8634*	X44076	1	103	SMALL LOWER FRONT - PRIOR TO J6050000	112
PANEL A.-SIDE RIGHT *8634*	X44078	1	103	SMALL LOWER FRONT - PRIOR TO J6050000	112
PANEL-REAR *8634 AIR*	048208	1	103	J4070000/UP	84

+ Available Separately

DESCRIPTION	PART NUMBER	QTY.	WARR. CLASS	REMARKS	PARTS UPDATE
PANEL-REAR *8634 AIR*	044054	1	103	J4070000/PRIOR (SEE KIT X48208-SER)	84
PANEL-UPPER SIDE	051631	1	103	LEFT SIDE - J7120000/UP	125
PANEL-UPPER SIDE	024426	1	103	LEFT SIDE - PRIOR TO J7120000	125
PANEL-UPPER SIDE	051632	1	103	RIGHT SIDE - J7120000/UP	125
PANEL-UPPER SIDE	044049	1	103	RIGHT SIDE - PRIOR TO J7120000/UP	125
PCB A.-CONTROL *PH90* UVC2 (NEW)	X53749-SER	1	212	J9101985/UP	147
Includes:					
CHIP-SOFTWARE *PH90* UVC2	X40792	1	103	J9101985/UP	147
PCB A.-UVC2	X51169-SER	1	212	BASE BOARD - J9101985/UP	147
IC-PARALLEL PORT CHIP	040176-006	1	103		147
PCB A.-CONTROL *PH90* (OLD)	X48363-SER	1	212	PRIOR TO J9101985 (REPLACED W/X53749-SER)	93/147
Includes:					
CHIP-SOFTWARE *PH90*	X40857	1	103	PRIOR TO J9101985	147
PCB A.-UNIVERSAL CONTROL 64K	X44863-SER	1	212	BASE BOARD - PRIOR TO J9101985	147
IC-PARALLEL PORT CHIP	040176-006	1	103		
PCB A.-INTERFACE-HT-SHAKE	X44745-SER	1	212	SHAKE	
Includes:					
PCB A.-INTERFACE-HT-BASE	X44747-SER	1	212	BASE BOARD	
PCB A.-PERSONALITY-HT-SHAKE	X44748-SER	1	212		
PCB A.-INTERFACE-HT-SS	X47048-SER	1	212	SOFT SERVE	
Includes:					
PCB A.-INTERFACE-HT-BASE	X44747-SER	1	212	BASE BOARD	
PCB A.-PERSONALITY-HT-SS	X46904-SER	1	212		
PCB A.-LED-4 POSITION	X44752-SER	2	103		
PLATE A.-DEC-8634-PRTL	X45225	1	103		
PLUG-Q.D. CO2 1/8 MP	021077	4	103	SYRUP TANK	
PLUG-Q.D. LIQ. 3/4-18 FP	021081	4	103	SYRUP TANK	
+INSERT-Q.D. PLUG	021081-1	4	103	FOR Q.D. PLUG	
PLUG-SYRUP HOLE	026278	4	000	SHAKE DOOR	
PROBE A.-MIX LOW-HT	X42077	2	103	MIX LOW	
PROBE A.-MIX OUT-SQUARE HOLE	X41348	2	103	MIX OUT	

+ Available Separately

DESCRIPTION	PART NUMBER	QTY.	WARR. CLASS	REMARKS	PARTS UPDATE
PROBE-THERMISTOR-BARREL-2% TOL	038061-BLK	2	103	BARREL	
PROBE-THERMISTOR-HOPPER-2% TOL	039470-BLK	3	103	HOPPER AND HEATER	
PULLEY-AGT MTR-1.910PDX3/8BORE	042063	1	103	AGITATOR MOTOR	
+SCREW-8-32 X 1/4 ALLEN SET	043603	1	000		
PULLEY-2AK22 X .625-.6265	016403	1	103	SOFT SERVE BEATER MOTOR	
PULLEY-2AK74-5/8	027822	1	103	SOFT SERVE GEAR	
PULLEY-AGT DR-1.910PDX5/16 THD	036210	3	103	AGITATOR DRIVE	
+SCREW-8-32 X 1/4 ALLEN SET	043603	3	000		
PULLEY-AK25-5/8	019153	1	103	SHAKE BEATER MOTOR	
PULLEY-AK64-5/8	007538	1	103	SHAKE GEAR	
PUMP A.-COAX *HPR*SH*A*	X45788-A	1	103	SHAKE	
BODY A.-COAX VALVE *HPR*SH*A	X46859-A	1	103		
+CLIP-MIX PUMP RETAINER	044641	1	103		
CYLINDER A.-PUMP-HOPPER-SHAKE	X44669	1	103		
O-RING-1-3/8 OD X .103W	018664	1	000		
O-RING-2-1/8 OD X .139W	020051	3	000		
O-RING-3/4 OD X .103W	015835	1	000		
PIN A.-COAX PUMP *HT*SS*	X36950	1	103		
+PIN-COTTER-HAIRPIN-1/8DIA	044731	1	103		
PISTON-COAX PUMP *A* WHITE	032733	1	103		
POPPET-RUBBER-BLACK	022473	1	000		
RING-CHECK 1-1/4 OD X 3/8	033215	1	000		
RING-CHECK 2 IN OD X 1/2	020050	2	000		
SEAL-AIR INLET FITTING	045327	1	000		
SPRING-TAPERED 1-7/8L	022456	1	103		
TUBE A.-MIX INLET-HOPPER PUMP	X45318	1	103		
PUMP A.-COAX *HPR*SS*B	X45316-B	1	103	SOFT SERVE	
BODY A.-COAX VALVE *HPR*SS*B	X46860-B	1	103		
+CLIP-MIX PUMP RETAINER	044641	1	103		
CYLINDER A.-PUMP *HT*MCD*SS	X44755	1	103		
O-RING-1-3/8 OD X .103W	018664	1	000		

+ Available Separately

DESCRIPTION	PART NUMBER	QTY.	WARR. CLASS	REMARKS	PARTS UPDATE
O-RING-2-1/8 OD X .139W	020051	3	000		
O-RING-3/4 OD X .103W	015835	1	000		
PIN A.-COAX PUMP *HT*SS*	X36950	1	103		
+PIN-COTTER-HAIRPIN-1/8DIA	044731	1	103		
PISTON-COAX PUMP *B*HPR	045319-B	1	103		
POPPET-RUBBER-BLACK	022473	1	000		
RING-CHECK 1-1/4 OD X 3/8	033215	1	000		
RING-CHECK 2 IN OD X 1/2	020050	2	000		
SEAL-AIR INLET FITTING	045327	1	000		
SPRING-TAPERED 1-7/8L	022456	1	103		
TUBE A.-MIX INLET-HOPPER PUMP	X45318	1	103		
PUMP A.-SYRUP-HEATED-BRN/TAN	X53800-	1	103	-BRN (CHOCOLATE) OR -TAN (CARMEL)	148
INSERT-PLUNGER	032758	1	103		
NOB-PLUNGER-BROWN/ TAN-SYRUP	032762-	1	103	-BRN OR -TAN	
LID-PUMP	036579	1	103		
NUT-LOCK-SYRUP PUMP	039680	1	103		
NUT-PLUNGER-SYRUP-PUMP	036577	1	103		
O-RING 9/16 OD	016369	1	000	NOB	
O-RING-13/16 OD X .103 W	019330	1	000	PLUNGER SEAL	
PLUNGER	036578	1	103		
PUMP A.-SYRUP HEATED	X53798-SER	1	103		
BODY A.-PUMP VALVE	054084	1	103	CAPTIVE BALL DESIGN	
CYLINDER-SYRUP PUMP	051065	1	103		
O-RING-1 ID X .103 W	048148	1	000	OUTLET TUBE	
O-RING-1-5/16 OD X .103 W	048149	1	000	PLUNGER TUBE	
SEAL ASSEMBLY	X33057	1	000		
O-RING-13/16 OD X .103 W	019930	1	000		
SPRING-PLUNGER	032761	1	000		
TUBE-PLUNGER	032757	1	103		
WASHER-NYLON	032760	1	000		
PUMP-GLYCOL-1/8NPT-1650 RPM	041785	1	112		

+ Available Separately

051103

DESCRIPTION	PART NUMBER	QTY.	WARR. CLASS	REMARKS	PARTS UPDATE
+ MOTOR ONLY	041785-1	1	112		
+ PUMP ONLY	041785-2	1	112		
+ MAGNET ONLY	041785-3	1	103		
+BOOT-GLYCOL PUMP	042131	1	000		
RELAY-3 POLE-20A-208/240 50/60	012725-	2	103	MAIN COMPRESSOR	
RELAY-MTR START T#4CR-1-625	039725-	1	103	SOFT SERVE MOTOR REDUCER	
RELAY-MTR START T#4CR-2-645	042007-	1	103	SHAKE MOTOR REDUCER	
RELAY-SPDT-30 A-240 V	032607-	1	103	GLYCOL HEATER	
RESTRICTOR-SYRUP	025816	3	000		
SAMPLER-SYRUP	045031	1	000		
SANITIZER KAY-5 125 PACKETS	041082	1	000		
SENSOR A.-EVC-SHAKE-60"	X44001	1	103		
SENSOR A.-PYROELECTRIC-42"L	X38977-SER	1	103		
SHAFT A.-DRIVE-MIX PUMP-HOPPER	X41947	2	103		
CRANK-DRIVE-HOPPER MIX PUMP	039235	1	103		
O-RING 1/2 ID X .139W-206	048632	2	000		
O-RING-1-3/4 OD X .139W	008904	1	000		
SHAFT-DRIVE-MIX PUMP-HOPPER	041948	1	103		
SHAFT-BEATER *7QT FLUTED BLADE	050985	1	103	SHAKE - USE W/ X50958 BEATER	113
+SEAL-DRIVE SHAFT	032560	1	000		
SHAFT-BEATER	032564	1	103	SOFT SERVE	
+SEAL-DRIVE SHAFT	032560	1	000		
SHELL A.-INSULATED *8634*	X45227-SER	1	512	INCLUDES STUDS	
STUD-FREEZER *8663*	034035	4	103	SHAKE	
STUD-NOSE CONE	022822	4	103	SOFT SERVE	
SHIELD-SPLASH	028548	1	103		
SHIELD-PYROELECTRIC SENSOR	039096	1	103		
SHROUD-SYRUP/AIR LINE-BLUE (OLD)	042503-BLU	1	000	PRIOR TO J9096706	145/146
SHROUD-SYRUP/AIR LINE-BROWN (OLD)	042503-BRN	1	000	PRIOR TO J9096706	145/146
SHROUD-SYRUP/AIR LINE-RED (OLD)	042503-RED	1	000	PRIOR TO J9096706	145/146
SHROUD-SYRUP/AIR LINE-WHITE (OLD)	042503-WHT	1	000	PRIOR TO J9096706	145/146

+ Available Separately

051103

DESCRIPTION	PART NUMBER	QTY.	WARR. CLASS	REMARKS	PARTS UPDATE
SLEEVE A.-MIX PUMP *HT*MCD	X44761	2	103		
+NUT-PUMP SLEEVE *8751*HT*	036933	2	103		
SPINNER *8663*	034054	1	103		
+SEAL-SPINNER SHAFT	036053	1	000		
SOCKET-Q.D. LIQ.-90DEG-1/4BARB	021026	4	103		
STARTER-BEATER LINE	041950-	2	103		
SWITCH A.-DRAW *321-750*SLFCLS	X33322-SP	1	103	SOFT SERVE	
ARM A.-DRAW *750-1-2*MC*	X33326	1	103		
BRACKET A.-SWITCH *321-751*	X43722	1	103		
E-RING	049178	1	000		
PIN-PIVOT	015478	1	103		
SPRING-RETURN-LEFT-SELF CLOSE	041660	1	103		
SPRING-RETURN-RIGHT-SELF CLOSE	041661	1	103		
SWITCH-LEVER-SPDT-10A-125-250V	028889	1	103		
SWITCH A.-DRAW *5472*	X45076-SER	1	103	SHAKE	
BEARING-SWITCH *482-8663*	034042	1	000		
BEARING-SWITCH *482-8663*	034043	2	000		
BRACKET A.-ACTUATOR *5472 HT*	X41882	1	103		
BRACKET A.-DRAW SWITCH *5472HT	X41879	1	103		
E-RING 1/4	032190	1	000		
NUT-PUSH ON-1/2DIA. SHAFT	039735	2	000	REPLACES 032580 RING-TRUARC	
ROD A.-DRAW *5472 HT*	X41880	1	103		
SWITCH-LEVER-SPDT-15A-125-250V	027214	1	103		
SWITCH-MEMBRANE-5 POSITION-8"L	044520	1	103		
SWITCH-MEMBRANE-5 POSITION-20"	044521	2	103		
SWITCH-PRESSURE 440 PSI-SOLDER	048230	2	103	J6040000/UP	105
SWITCH-PRESSURE 440 PSI-SOLDER	046362	2	103	J4047460 Thru J6039999 HP62	80 & 105
SWITCH-PRESSURE 25PS OPEN 405	030886	1	103	J4047459/PRIOR	80
+BOOT-PRESSURE SWITCH	034682	2	000		
SWITCH-TOGGLE-DPDT*ON-NONE-ON	024295	1	103	POWER	
SWITCH-TOGGLE-SPST	051974	2	103	SYRUP HEATER - 042782 - J8070000/UP	135

+ Available Separately

DESCRIPTION	PART NUMBER	QTY.	WARR. CLASS	REMARKS	PARTS UPDATE
SWITCH-TOGGLE-SPST	012626	2	103	SYRUP HEATER - 042782 PRIOR TO J8070000	
SYRUP RAIL ASSY SPARE PARTS					
HEATER-STRIP-175W-240V	042782	2	103		
LABEL-TEMPERATURE ADJUSTMENT	030994	2	000		
O-RING-9/16 OD X .103W	016369	3	000	DRAIN PLUG	
PLUG-DRAIN-WYOTT	023953-5	3	103		
THERMOSTAT-ADJ-SNAP ACTING	049993	2	103		104
THERMOSTAT-HI LIMIT-SNAP ACTING	049992	2	103		104
TANK-GLYCOL 1.5QT-PLASTIC	047314	1	103	J4020000/UP	79
CAP-GLYCOL TANK	047314-1	1	103	J4020000/UP	79
TANK-SYR-4 QT	045533	4	103		
COVER-XYRUP TANK W/ INLET FITTING	035759-1	4	103	INCLUDED W/ TANK	
+DECAL-SYRUP TANK INSTRUCTION	045533-1	4	000		
GASKET	016037	4	000	FOR COVER	
O-RING	018550	4	000	FOR DIP TUBE	
TIP-NYLON-WHITE	42747	8	000		
TUBE-DIP	015441-7	4	103		
TEE-ACCESS 1/2" W/5344 CORE	026688	1	103	12/09/96/ PRIOR	
TOOL-COAX PUMP LVB & DRIVE SHAFT REMOVAL	047919	1	000		
TOOL-SEAL INSTALL-REMOVE	035460	1	000		
TRANS.-240V PR1/24V SEC 10 VA	030132-	1	103	SHAKE SYRUP CONTROL VALVE	
TRANS.-CONT-.40VA 120/200/240V	045754	1	103	POWERS INTERFACE BOARDS	
TRAY-DRIP *8662-8663*	028542	1	103		
TRAY-PARTS-BARREL	044118	1	000	SHAKE - J7060000/UP	118
TRAY-PARTS-BARREL	045756	1	000	SOFT SERVE - J7060000/UP	118
TRAY-PARTS-PUMP	044117	2	000	J7060000/UP	118
TRIM-REAR CORNER-LEFT	044051	1	103		113
TRIM-REAR CORNER-RIGHT	044053	1	103		113
NUTSERT-10-32	047597	6	103	FOR REAR CORNER TRIM 4/30/99/ PRIOR	113
NUTSERT-10-32	053431	6	103	FOR REAR CORNER TRIM 5/01/99/ UP	

+ Available Separately

DESCRIPTION	PART NUMBER	QTY.	WARR. CLASS	REMARKS	PARTS UPDATE
TUBE A.-HEAT T.PUMP FEED	X44666	1	103	SOFT SERVE	
TUBE A.-HEAT T.PUMP FEED	X44615	1	103	SHAKE	
TUBE-.170 ID X .250 OD - SYRUP VALVE	075885-96	VAR	000	BULK UNDER R40302 (CUT TO LENGTH)	
TUBE-VINYL 1/4ID X 1/16 WALL	020941-	VAR	000	BULK UNDER R30312	
TUBE-VINYL 1/8ID X 1/16 WALL	020938-	VAR	000	BULK UNDER R30301	
VALVE A.-SYRUP CONTROL	X50561	1	103	J6061311/UP	107
DECAL-SET-SYRUP VALVES	045521	1	000		
FITTING-BARB SYRUP MANIFOLD	050493	1	103		
FITTING-ELBOW SYRUP MANIFOLD	050492	1	103	FOR 075885-8 AIR TUBE	
FITTING-BARB MEAD VALVE	050494	5	103	FOR 020938-17 VINYL TUBE	
MANIFOLD-SYRUP VALVE	050496	1	103		
PLUG-VALVE SYRUP 5 BLOCK	050302-01	1	000	SMALL WHITE PLASTIC - SIDE PLUG	137
TUBE-VINYL 1/8ID X 1/16 WALL	020938-17	4	000	BULK R30301	
VALVE-SYRUP 5 BLOCK	050302	1	103		
VALVE-SOLENOID-3 WAY 12 VDC	050490-02	1	103	AIR	
VALVE-SOLENOID-3 WAY 24 VAC	050490-03	4	103	SYRUP	
VALVE-ACCESS 1/4FL X 5/16S - 90 DEG. ELBOW	053027	2	103	J9090000/UP (FRENCH BUILT COMPRESSOR)	146
VALVE-ACCESS 1/4 FL X 3/8S	044455	2	103	PRIOR TO J9090000	146
VALVE-ACCESS 1/4FL X 3/8SOLDER	043232	2	103		
VALVE-ACCESS-1/4 MFLX1/4 S-90	047016	2	103	J4047460/UP HP62	80
VALVE-EXP-AUTO-1/4S X1/4 FPT	046365	2	103	J4047460/UP HP62	80
+BOOT-EXPANSION VALVE	050900	2	000		
VALVE-EXP-AUTO-1/4MF X 1/4 FPT	037392	2	103	J4047459/PRIOR	80
+BOOT-EXPANSION VALVE	027137	2	000		
VALVE-SOLENOID 3-W 1/4FPT 240V	037954-	2	103	GLYCOL HEATER	
+ COIL-SOLENOID VALVE	037954-27C	2	103	COIL ONLY	
VIDEO-TRAIN FILM-HT	045804-V	1	000	J4070000/UP	83

+ Available Separately

DESCRIPTION	PART NUMBER	QTY.	WARR. CLASS	REMARKS	PARTS UPDATE
WATER COOLED					
BLOWER-100CFM	012796-	1	103		
CONDENSER-W/C-COAXIAL	047540	2	103	J4047460/UP HP62	80
CONDENSER-W/C COAXIAL	031651	2	103	J4047459/PRIOR	80
ELBOW-3/8MP X 1/2 BARB-BRASS	018641	2	103		
GUARD-BLOWER	022505	1	103		
OUTLET A-TEE	X25900	1	103		
PANEL-REAR	048210	1	103	J4070000/UP	84
PANEL-REAR	044631	1	103	J4070000/PRIOR (SEE KIT X48210-SER)	84
RUBBER HOSE 1/2" ID X 7/8"	R50200	12FT	000	ORDER IN BULK	
SWITCH-PRESSURE 350 PSI	048231	2	103	J6040000/UP	105
SWITCH-PRESSURE 350 PSI	046431	2	103	J4047460 Thru J6039999 HP62	80 & 105
SWITCH-PRESSURE 25PS OPEN 405I	030886	2	103	J4047459/PRIOR	80
TEE-3/8" PIPE-WATER VALVE	032953	1	103		
VALVE-WATER 3/8 REG HEAD	046686	2	103	J4047460/UP HP62	80
VALVE-WATER 3/8 HEAD	008363	2	103	J4047459/PRIOR	80
50 CYCLE					
BELT-AX34	025729	2	000	SOFT SERVE	
BELT-V-4L330	027016	1	000	SHAKE - J8039999/PRIOR	129
BELT-AX31	041575	1	000	SHAKE - J8040000/UP	129
BLOCK-TERMINAL 3P+N	039424	1	103		
BLOCK-TERMINAL-7 POLE GREEN	024156	2	103		
MOTOR-REDUCER	044723-34	1	103	SHAKE	
GEAR-ONLY	049245-34	1	103	SHAKE	
MOTOR-ONLY	049244-34	1	103	SHAKE	
PULLEY-2AK27 X .625-.6265	011545	1	103	SOFT SERVE BEATER MOTOR	
PULLEY-AGT DR-1.690PDX5/1	045717	1	103		
PULLEY-AGT DR-1.910PDX5/16 THD	036210	2	103		
PULLEY-AGT MTR-2.110PDX3	045718	1	103	AGITATOR MOTOR	
PULLEY-AK30 X 5/8	033559	1	103	SHAKE BEATER MOTOR	

+ Available Separately

DESCRIPTION	PART NUMBER	QTY.	WARR. CLASS	REMARKS	PARTS UPDATE
STARTER-3 PHASE 1.4 TO 2.3A	041950-33G	1	103	SHAKE 50Hz 3 PHASE	
STARTER-3 PHASE 2.0 TO 3.3A	041950-33H	1	103	SOFT SERVE 50Hz 3 PHASE	

+ Available Separately

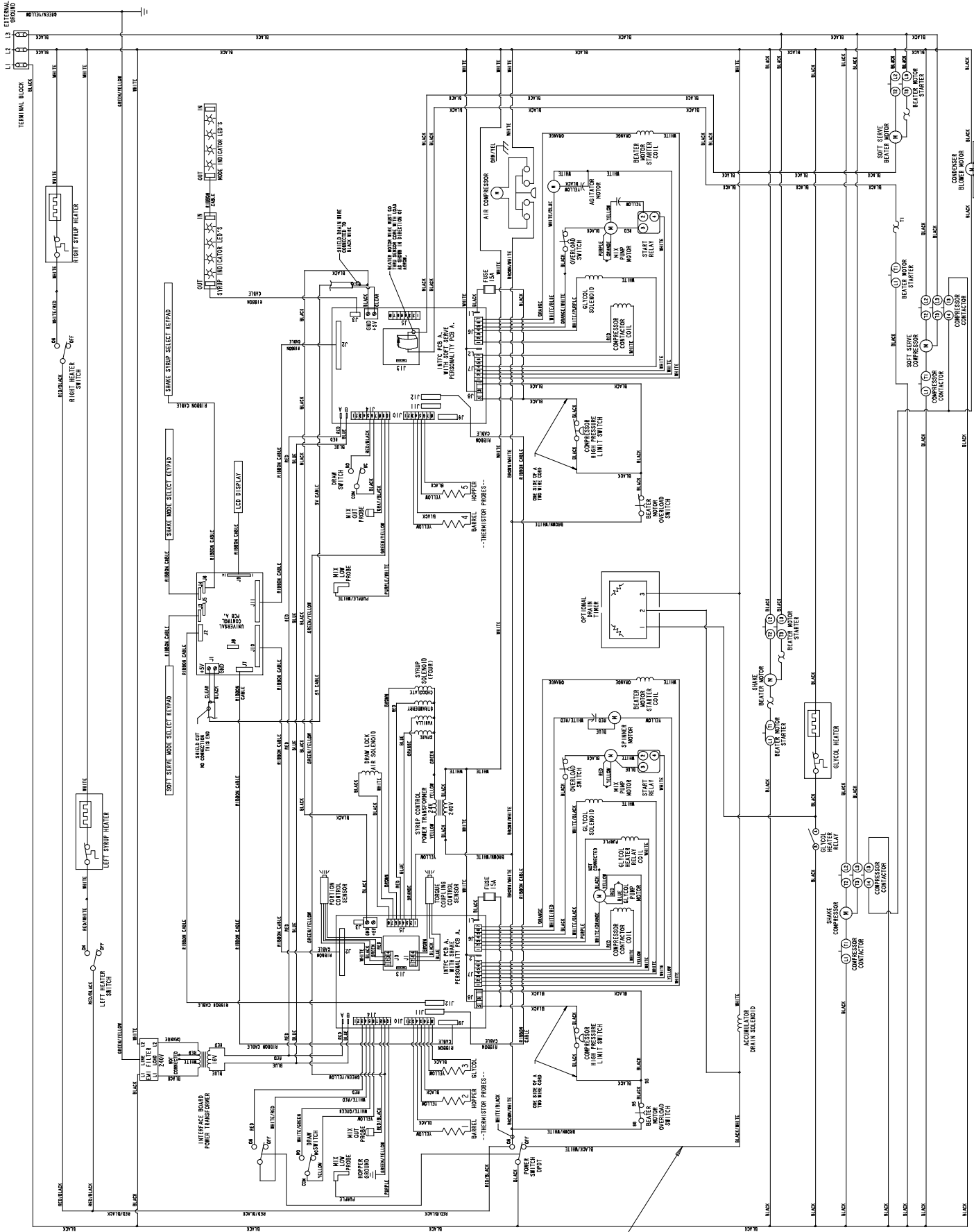

REMOVE THIS WIRE WHEN ADDING THE OPTIONAL DRAIN TIMER

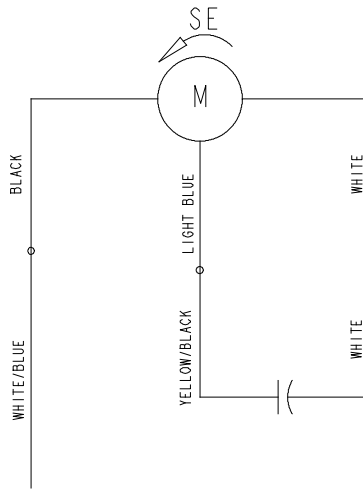

AGITATOR MOTOR DETAIL

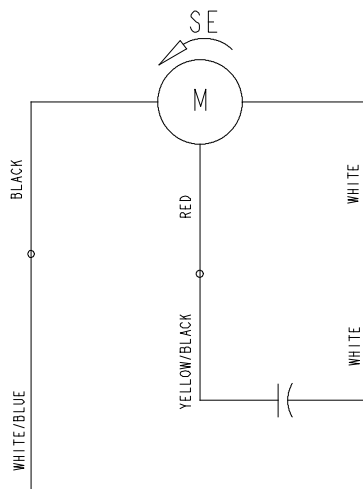

ALTERNATE AGITATOR MOTOR DETAIL

GROUND FRAME SECURELY

NOTE:

1. STATIC ELECTRICITY MAY CAUSE DAMAGE TO SOLID STATE COMPONENTS. ELIMINATE STATIC ELECTRICITY BY TOUCHING GROUNDED UNIT BEFORE HANDLING SOLID STATE COMPONENTS.
2. RED WIRE ON RIBBON CABLES MUST BE CONNECTED TO PIN 1 AT EACH END.

